



Equipos
de Bombeo

Barmesa®

¡Líderes en Calidad!



Bombas Centrífugas
Multietapas Verticales
BMV/BMVF

▶ **ÍNDICE**

▶ APLICACIONES Y CONDICIONES DE OPERACIÓN	1
▶ COBERTURA HIDRÁULICA	1
▶ NOMENCLATURA	1
▶ NPHS	2
▶ INSTALACIÓN EN PARALELO	3
▶ MOTORES ELÉCTRICOS	3
▶ MÁXIMA PRESIÓN DE ENTRADA	3
▶ MATERIALES DE CONSTRUCCIÓN	5
▶ CURVA DE RENDIMIENTO BMV1	6
▶ CURVA DE RENDIMIENTO BMV2	7
▶ CURVA DE RENDIMIENTO BMV3	8
▶ CURVA DE RENDIMIENTO BMV4	9
▶ CURVA DE RENDIMIENTO BMV8	10
▶ CURVA DE RENDIMIENTO BMV12	11
▶ CURVA DE RENDIMIENTO BMV16	12
▶ CURVA DE RENDIMIENTO BMV20	13
▶ CURVA DE RENDIMIENTO BMV32	14
▶ CURVA DE RENDIMIENTO BMV42	15
▶ CURVA DE RENDIMIENTO BMV65	16
▶ CURVA DE RENDIMIENTO BMV90	17
▶ CURVA DE RENDIMIENTO BMV120	18
▶ CURVA DE RENDIMIENTO BMV150	19
▶ CURVA DE RENDIMIENTO BMV200	20

▶ APLICACIONES Y CONDICIONES DE OPERACIÓN

La bomba BMV está diseñada para manejar líquidos limpios. Su versatilidad es máxima, en tanto que puede manejar agua limpia o líquidos industriales a diferentes temperaturas y condiciones de operación muy variadas.

- ▶ Sistemas de presión constante
- ▶ Sistemas de osmosis inversa
- ▶ Sistemas de destilación
- ▶ Sistemas de filtrado
- ▶ Sistemas de riego
- ▶ Sistemas contra incendio
- ▶ Sistemas de aire acondicionado
- ▶ Sistemas de condensación
- ▶ Sistemas de lavado de alta presión
- ▶ Sistemas de suministro de agua limpia
- ▶ Sistemas de alimentación a calderas
- ▶ Capacidades hasta 1667 LPM
- ▶ Cargas hasta 250 m
- ▶ Temperaturas hasta 70° C (de 70 a 120° C, consultar con su distribuidor).
- ▶ Líquidos limpios
- ▶ Líquidos no explosivos
- ▶ Líquidos no inflamables
- ▶ Líquidos no fibrosos
- ▶ Líquidos de baja viscosidad

▶ COBERTURA HIDRÁULICA

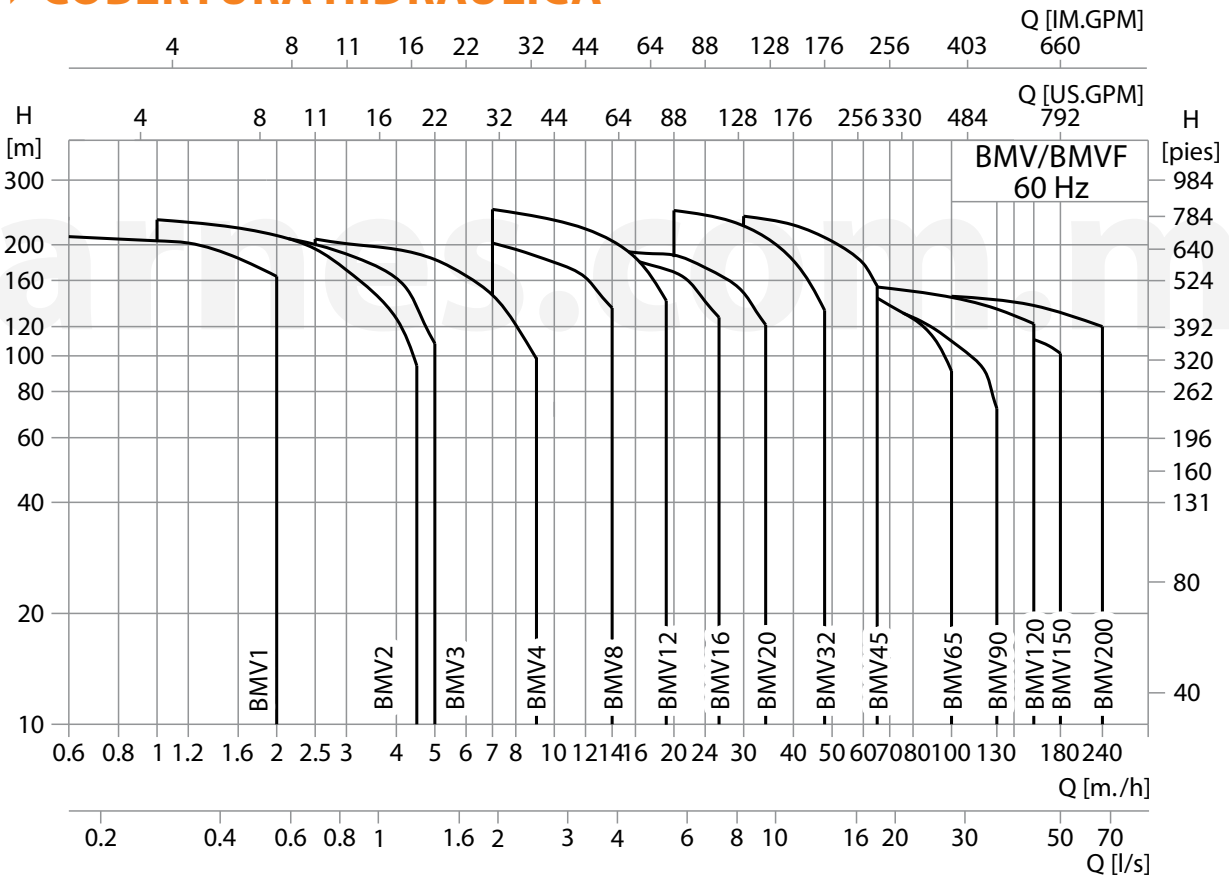

▶ NOMENCLATURA

BMVF1 - 250 - 303

FASE
 HP
 NÚMERO DE ETAPAS (x10)
 FLUJO NOMINAL (m³/h)
 SUCCIÓN Y DESCARGA EN HIERRO
 BOMBA MULTIETAPAS VERTICAL

► NPSH_R

- Es la carga de succión neta positiva requerida por la bomba, o dicho de otra manera, es la presión necesaria a la entrada de la bomba para evitar la cavitación.

En el sistema que se muestra: $NPSH_D = P_B - H - P_v - H_f$

Siendo:

- **NPSH_D** = carga de succión neta positiva disponible (pies).
- **P_B** = presión barométrica (lb/pulg.²). En la imagen de ejemplo, este valor es igual a 14.7 PSI (por ser un sistema abierto).
- **H** = altura máxima de succión (es la altura en pies del ojo del impulsor sobre o bajo el nivel del agua).
- **P_v** = presión de vapor. Este dato deberá obtenerse de tablas de presión de vapor - temperatura (ver Tabla 1).
- **H_f** = pérdida por fricción (en pies) en la tubería de succión.

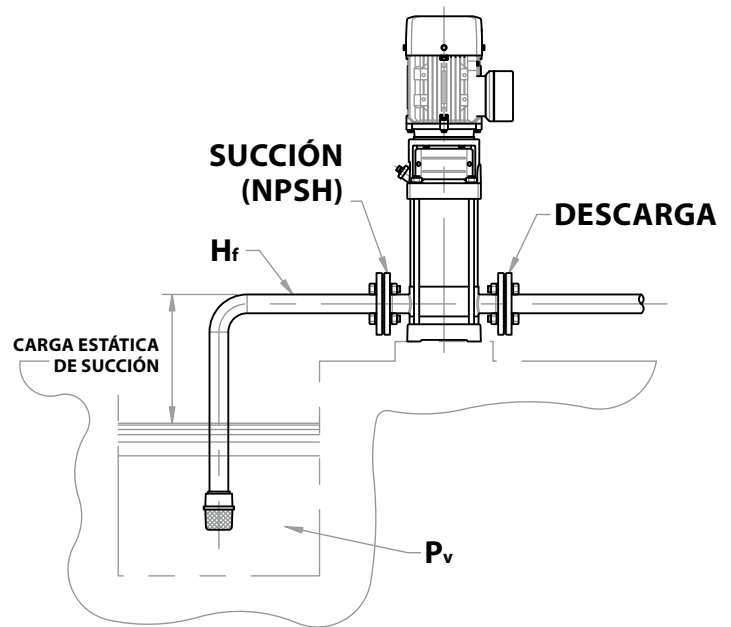

De la fórmula anterior podemos calcular la altura máxima de succión H, si este valor es positivo, la bomba puede operar a esta altura máxima. En caso de que H sea negativa, entonces se requerirá una presión de succión de por lo menos "H" pies.

Es importante calcular la altura máxima de succión cuando se manejan líquidos calientes, cuando la pérdida por fricción en la tubería de succión es alta o cuando el agua es succionada desde grandes profundidades. Debemos siempre asegurar que habrá una mínima presión del lado de la bomba, lo cual nos garantizará que no habrá cavitación.

En cualquier sistema hidráulico, el NPSH disponible del sistema debe ser mayor que el requerido.

Tabla 1: Presión de vapor - temperatura.

Temp. °F	Temp. °C	Presión de vapor PSI Abs	Presión de vapor Pies Abs
32	0	0.0885	0.204
40	4.4	0.1217	0.281
45	7.2	0.1475	0.34
50	10	0.1781	0.411
55	12.8	0.2141	0.494
60	15.6	0.2563	0.591
65	18.3	0.3056	0.706
70	21.1	0.3631	0.839
75	23.9	0.4298	0.994
80	26.7	0.5069	1.172
85	29.4	0.5959	1.379
90	32.2	0.6982	1.617
95	35	0.8153	1.89
100	37.8	0.9492	2.203
110	43.3	1.275	2.965

Temp. °F	Temp. °C	Presión de vapor PSI Abs	Presión de vapor Pies Abs
120	48.9	1.692	3.943
130	54.4	2.223	5.196
140	60	2.889	6.766
150	65.6	3.718	8.735
160	71.1	4.741	11.172
170	76.7	5.992	14.178
180	82.2	7.51	17.825
190	87.8	9.339	22.257
200	93.3	11.526	27.584
212	100	14.696	35.353
220	104.4	17.186	41.343
240	115.6	24.97	60.77
260	126.7	35.43	87.05
280	137.8	49.2	122.18
300	148.9	67.01	168.22

► INSTALACIONES EN PARALELO

Son sistemas constituidos por dos o más bombas operando simultáneamente, con sus descargas conectadas a una línea común. Una instalación de este tipo, es aplicable cuando el sistema demanda un flujo variable.

Si una bomba llegase a presentar alguna falla, el suministro de agua está garantizado, ya que sólo una parte del sistema es afectado.

El uso de dos o más bombas, en lugar de una, permite que cada una de ellas trabaje en su mejor región de eficiencia la mayor parte del tiempo de operación, aún cuando los costos iniciales pueden ser mayores; el costo de operación más bajo y la mayor flexibilidad puede resultar la decisión más económica.

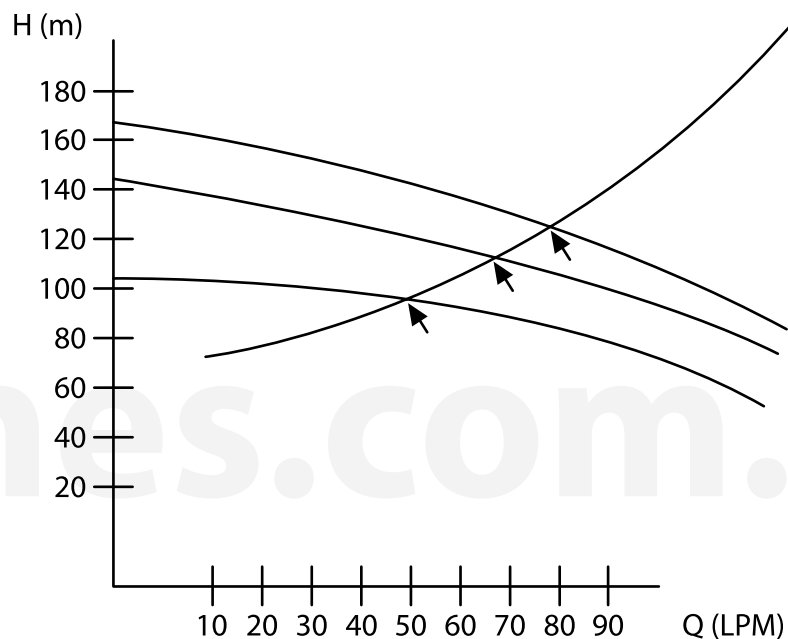

Las bombas trabajan en el punto de intersección de la curva de la bomba y la curva del sistema.

► MOTORES ELÉCTRICOS EFICIENCIA PREMIUM

- › Totalmente cerrados con ventilador exterior.
- › 2 polos, 3 fases, 60 ciclos, 230 / 460 volts.
- › Protección IP55.
- › Aislamiento clase "F".

► MÁXIMA PRESIÓN DE ENTRADA

Los valores de presión máxima de entrada se muestran en la siguiente tabla. La presión de entrada más la presión a válvula cerrada de la bomba deberá ser menor que la máxima presión de trabajo.

Tabla 2: Presión máxima.

MODELO	MÁX. PRESIÓN DE ENTRADA (bar)	MÁX. PRESIÓN DE TRABAJO (curva)
BMV1		
90 - 103	10	A
110 - 153	10	A
130 - 153	10	A
170 - 203	10	B
210 - 303	10	B
230 - 303	10	B
BMV2		
60 - 153	10	A
70 - 203	10	A
110 - 303	15	B
150 - 403	15	B
180 - 503	15	B
BMV3		
80 - 153	10	A
110 - 203	10	A
150 - 303	10	A
170 - 303	10	B
190 - 403	10	B
230 - 403	15	B
250 - 503	15	B
BMV4		
60 - 303	10	A
80 - 403	10	A
100 - 503	15	A
120 - 503	15	B
160 - 753	15	B
BMV8		
50 - 403	6	A
60 - 503	10	A
80 - 753	10	A
100 - 1003	10	C
120 - 1003	10	C
140 - 1503	10	C
BMV12		
20-303	25	C
30-503	25	C
50-753	25	C
70-1003	25	C
100-1503	25	C
140-2003	25	C

MODELO	MÁX. PRESIÓN DE ENTRADA (bar)	MÁX. PRESIÓN DE TRABAJO (curva)
BMV16		
40 - 1003	10	A
60 - 1503	10	A
80 - 2003	10	C
100 - 2503	10	C
BMV20		
40-1003	20	C
60-1503	20	C
80-2003	20	C
100-2503	20	C
BMV32		
32 - 1003	4	A
42 - 1503	10	A
52 - 2003	10	A
60 - 2503	10	D
82 - 3003	15	D
90 - 4003	15	D
BMV42		
20 - 2003		A
30 - 2503	10	A
42 - 3003	10	D
40 - 4003	10	D
50 - 4003	15	D
60 - 5003	15	D
BMV65		
20 - 3003	10	A
30 - 4003	15	A
42 - 5003	15	D
52 - 6003	15	D

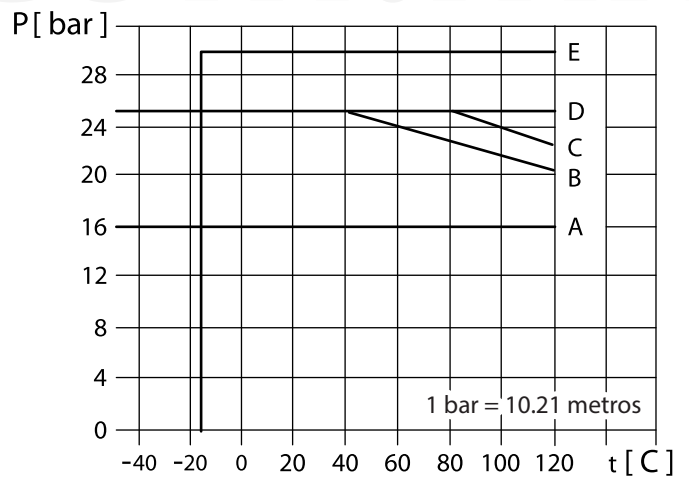

► NOTAS

1. Esta bomba no puede operar contra válvula cerrada, puesto que causaría un incremento en la temperatura y vapor, lo cual puede destruir la bomba.

2. En el caso de bombear líquidos con gravedad específica y/o viscosidad mayor a 1, se debe corregir la potencia del motor.

► MATERIALES DE CONSTRUCCIÓN

BMV1, BMV2, BMV3, BMV4

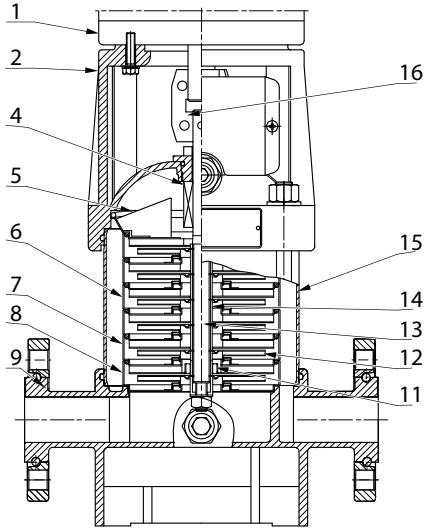

BMV1-20

ITEM	DESCRIPCIÓN	MATERIAL	DESIGNACIÓN
1	Motor		
2	Cabezal de bomba	Hierro gris	ASTM 25B
4	Sello Mecánico	Carbón / Carburo de tungsteno / Viton / Inox304	
5	Difusor superior	Acero inox.	AISI 304
6	Difusor	Acero inox.	AISI 304
7	Soporte de difusor	Acero inox.	AISI 304
8	Inductor	Acero inox.	AISI 304
9	Cámara de Succión y Descarga	Hierro gris	ASTM 25B
11	Balero	Carburo de tungsteno	
12	Impulsor	Acero inox.	AISI 304
13	Flecha	Acero inox.	AISI 304/16L
14	Manguito	Acero inox.	AISI 304
15	Cilindro	Acero inox.	AISI 304
16	Acoplamiento	Acero al carbón	

BMV8, BMV12, BMV16, BMV20

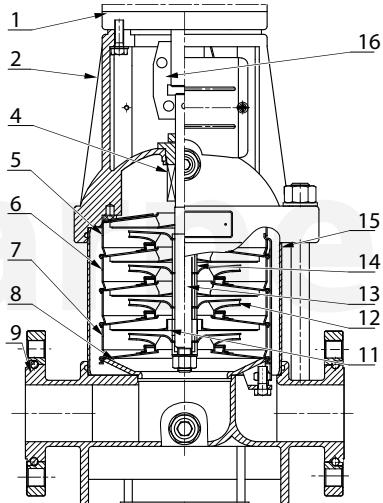

BMV32-85

ITEM	DESCRIPCIÓN	MATERIAL	DESIGNACIÓN
1	Soporte	Hierro gris	ASTM 25B
2	Cabezal de bomba	Acero inox.	AISI 304
3	Sello Mecánico	Carbón / Carburo de tungsteno / Viton / Inox304	
4	Difusor superior	Acero inox.	AISI 304
5	Soporte de difusor	Acero inox.	AISI 304
6	Difusor	Acero inox.	AISI 304
7	Inductor	Acero inox.	AISI 304
8	Cámara de Succión y Descarga	Acero inox.	AISI 304
9	Placa base	Hierro gris	ASTM 25B
10	Balero inferior	Carburo de tungsteno	
11	Impulsor	Acero inox.	AISI 304
12	Flecha	Acero inox.	AISI 304 AISI 316L AISI 1431
13	Balero intermedio	Carburo de tungsteno	
14	Cilindro	Acero inox.	AISI 304
15	Acoplamiento	Acero al carbón	
	Partes de caucho	NBR	

BMV32, BMV42, BMV65, BMV85

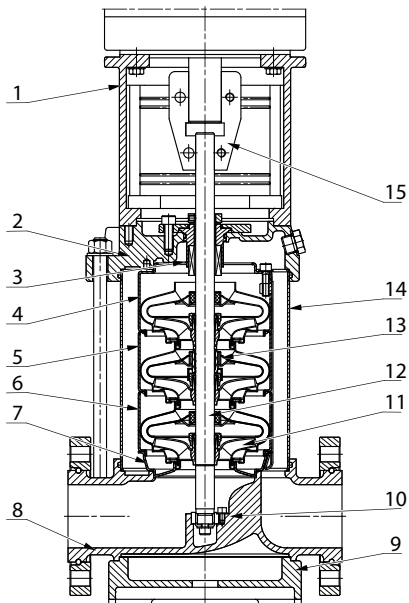

► CURVA DE RENDIMIENTO BMV1

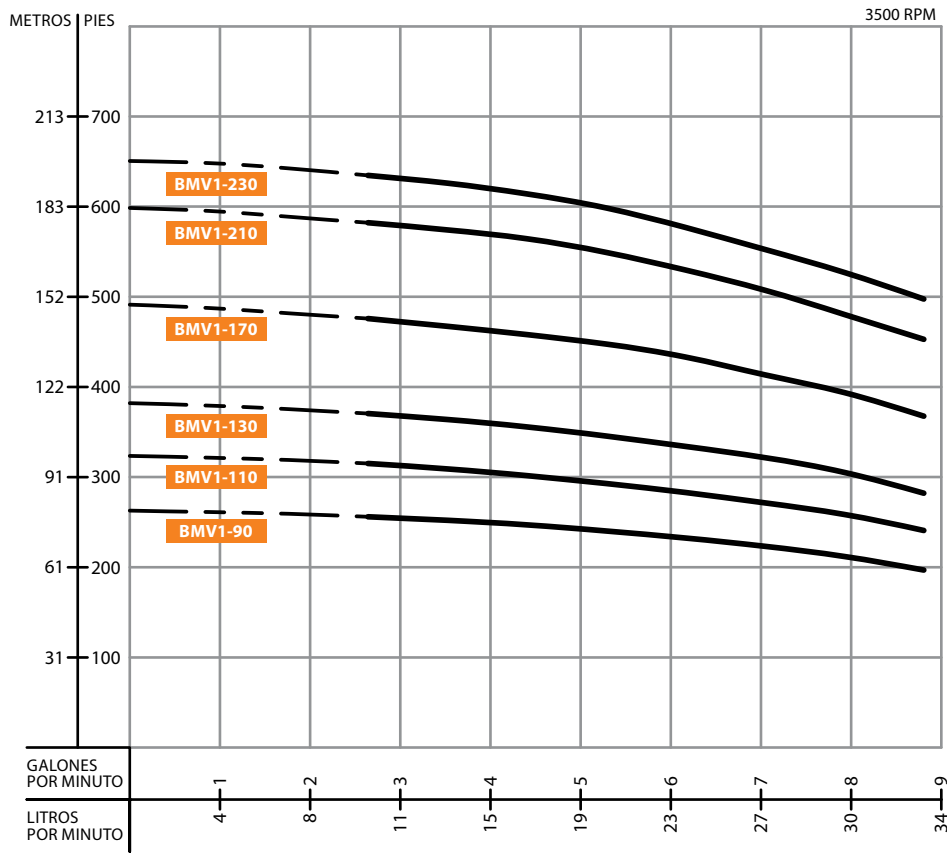

Dibujo de Instalación (mm)



Tabla de Rendimiento

MODELO	PASOS	HP	Q (LPM)	10	13.3	16.7	20	23.3	26.7	30	33.3
BMV1-90-103	9	1	H (m)	76	75	74	73	71	66	64	60
BMV1-110-153	11	1.5		95	93	90	87	85	81	78	73
BMV1-130-153	13	1.5		112	110	107	105	100	95	93	86
BMV1-170-203	17	2		144	141	139	137	132	124	120	112
BMV1-210-303	21	3		177	174	172	168	162	153	147	138
BMV1-230-303	23	3		193	190	188	184	174	167	161	152

Dimensiones y Pesos

TAMAÑO (mm)					PESO (kg)
B1	B2	B1+B2	D1	D2	
394	245	639	170	142	28
430	245	675	170	142	29
466	245	711	170	142	31
548	290	838	190	155	38
620	290	910	190	155	42
656	290	946	190	155	43

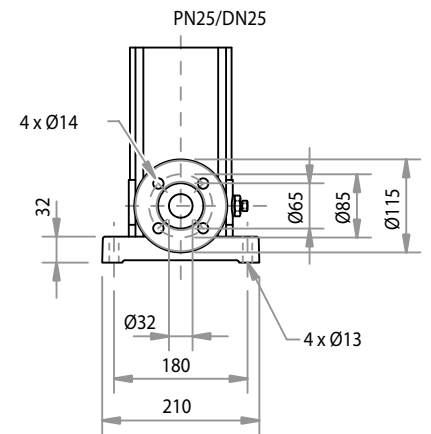
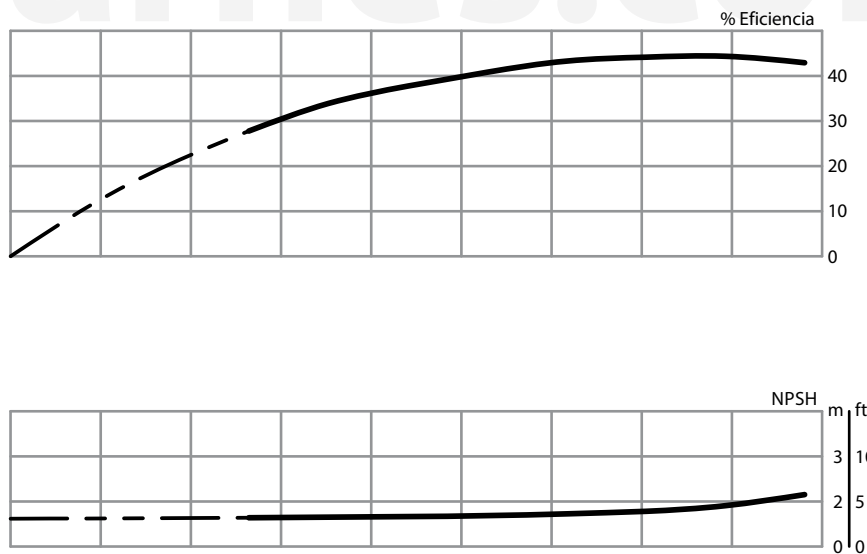
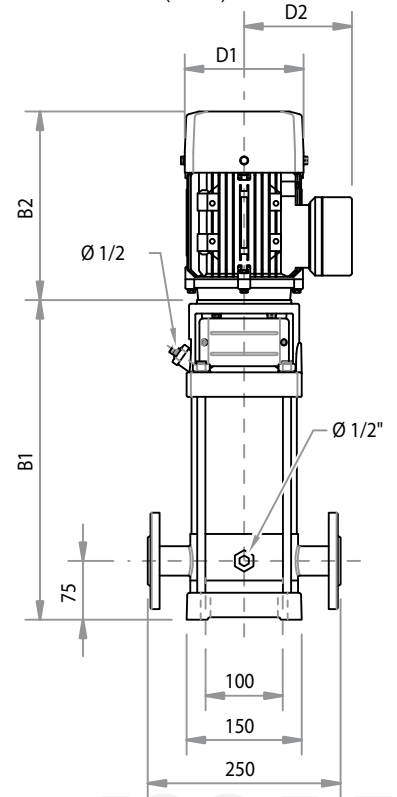
► CURVA DE RENDIMIENTO BMV2

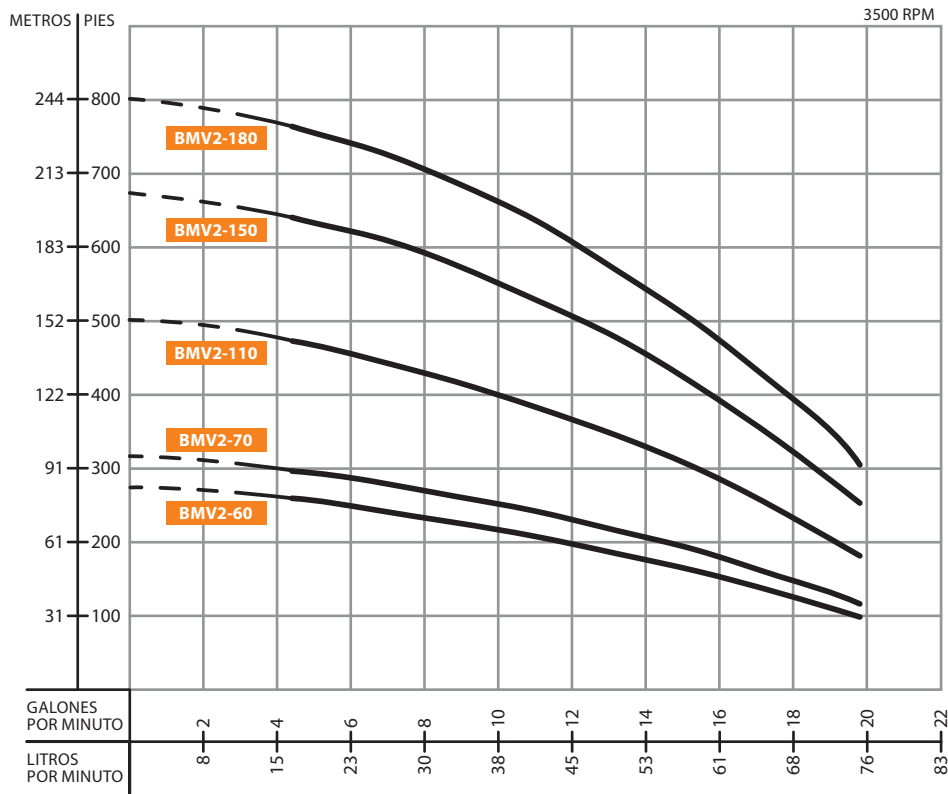

Dibujo de Instalación (mm)



Tabla de Rendimiento

MODELO	PASOS	HP	Q (LPM)	16.7	25	33.3	41.7	50	58.3	66.7	75
BMV2-60-153	6	1.5	H (m)	78	74	69	63	56	49	40	30
BMV2-70-203	7	2		91	86	81	74	66	57	47	35
BMV2-110-303	11	3		143	136	128	116	104	90	75	56
BMV2-150-403	15	4		195	186	176	160	142	125	103	77
BMV2-180-503	18	5.5		234	228	212	195	171	151	126	94

Dimensiones y Pesos

B1	TAMAÑO (mm)				PESO (kg)
	B2	B1+B2	D1	D2	
340	245	585	170	142	26
368	290	658	190	155	32
440	290	730	190	155	37
522	315	837	197	165	45
576	335	911	230	188	54

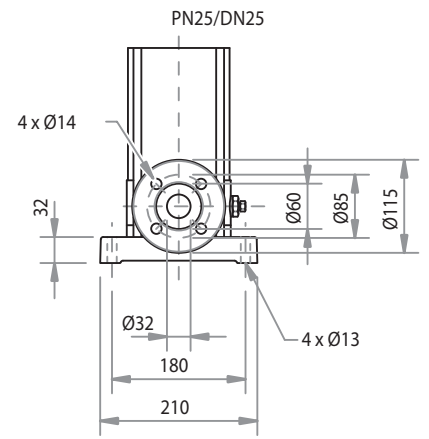
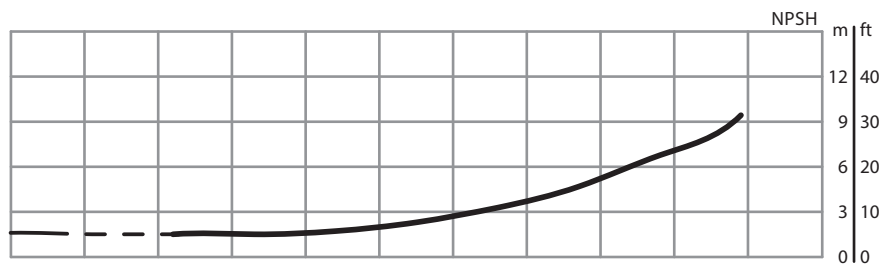
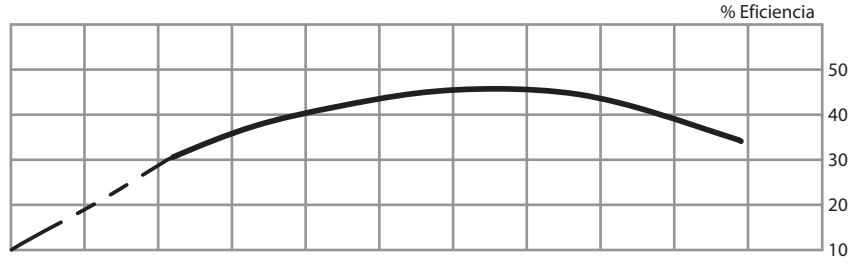
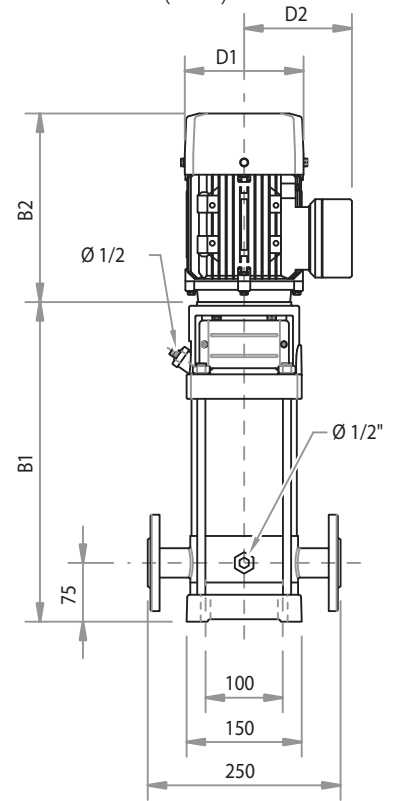
► CURVA DE RENDIMIENTO BMV3

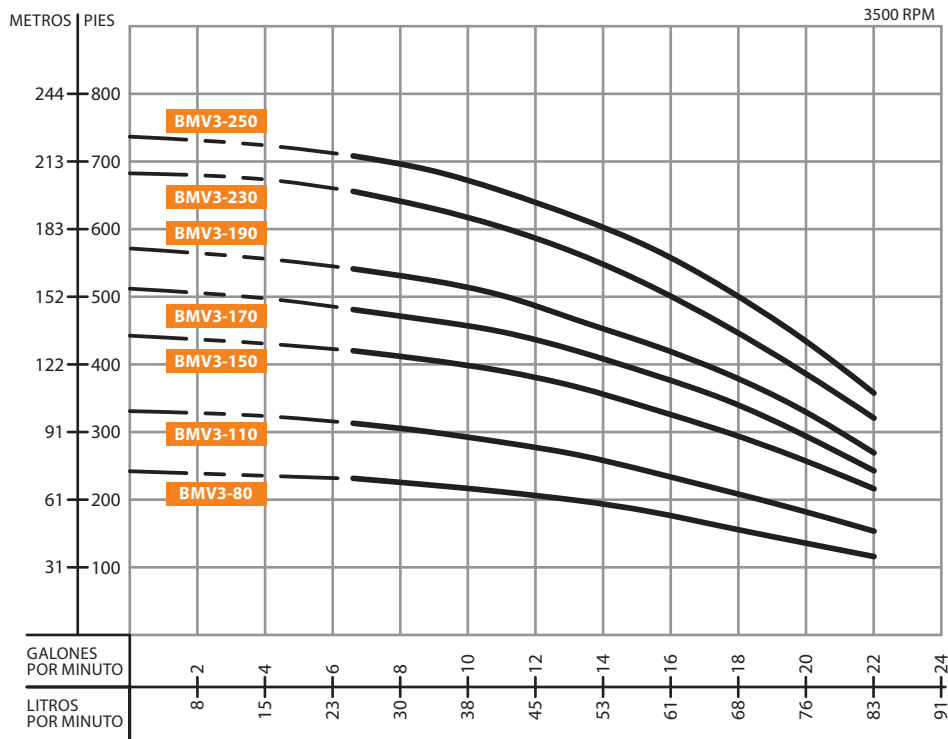

Dibujo de Instalación (mm)



Tabla de Rendimiento

MODELO	PASOS	HP	Q (LPM)	25	33.3	41.7	50	58.3	66.7	75	83.3
BMV3-80-153	8	1.5	H (m)	70	67	64	61	53	49	44	35
BMV3-110-203	11	2		96	92	87	82	74	69	59	48
BMV3-150-303	15	3		129	126	120	112	99	93	81	65
BMV3-170-303	17	3		147	143	137	128	114	106	91	74
BMV3-190-403	19	4		165	160	153	142	123	118	102	82
BMV3-230-403	23	4		200	194	185	174	154	142	122	98
BMV3-250-503	25	5.5		217	211	202	187	167	154	134	108

Dimensiones y Pesos

B1	B2	B1+B2	TAMAÑO (mm)		PESO (kg)
			D1	D2	
376	245	621	170	142	27
440	290	730	190	155	34
512	290	802	190	155	39
548	290	838	190	155	40
594	315	909	197	165	48
666	315	981	197	165	50
702	335	1037	230	188	58

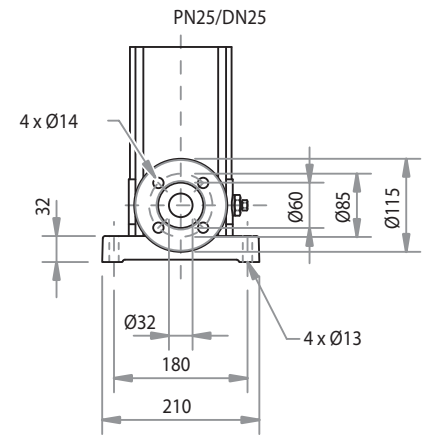
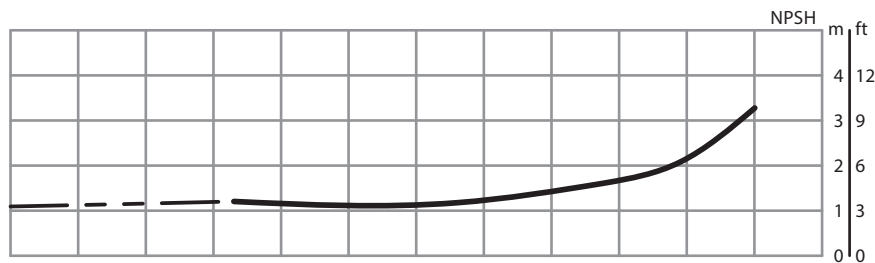
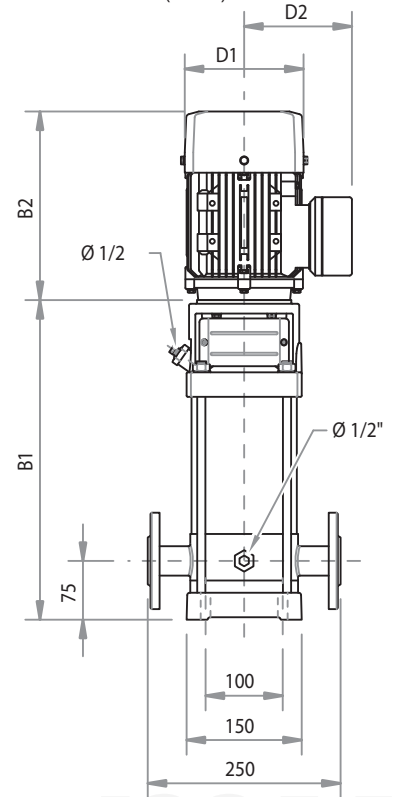
► CURVA DE RENDIMIENTO BMV4

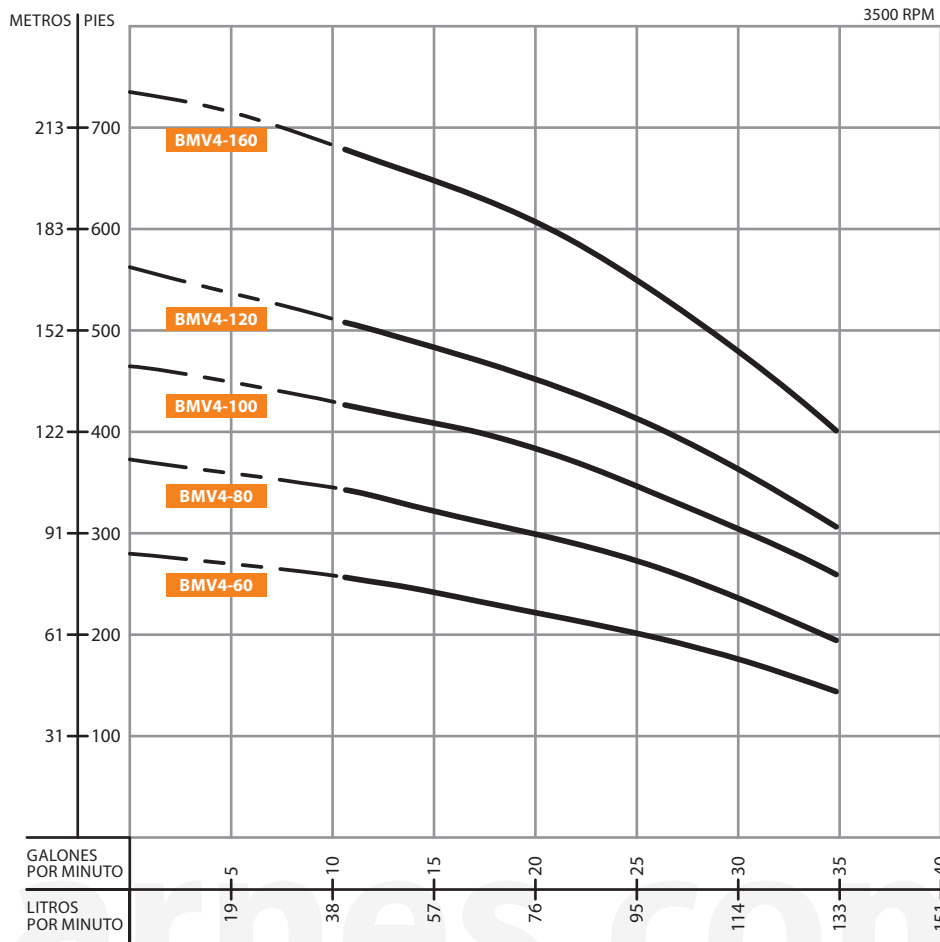

Dibujo de Instalación (mm)



Tabla de Rendimiento

MODELO	PASOS	HP	Q (LPM)	41.7	50	66.7	83.3	100	116.7	133.3
BMV4-60-303	6	3	H (m)	78	75	72	67	59	54	47
BMV4-80-403	8	4		104	100	95	90	79	72	63
BMV4-100-503	10	5.5		130	125	120	113	102	90	80
BMV4-120-503	12	5.5		156	150	145	136	122	109	96
BMV4-160-753	16	7.5		207	201	196	183	165	146	128

Dimensiones y Pesos

	TAMAÑO (mm)					PESO (kg)
	B1	B2	B1+B2	D1	D2	
BMV4-60-303	404	290	694	190	155	35
BMV4-80-403	468	345	813	197	165	42
BMV4-100-503	522	335	857	230	188	51
BMV4-120-503	576	335	911	230	188	52
BMV4-160-753	704	430	1134	260	208	66

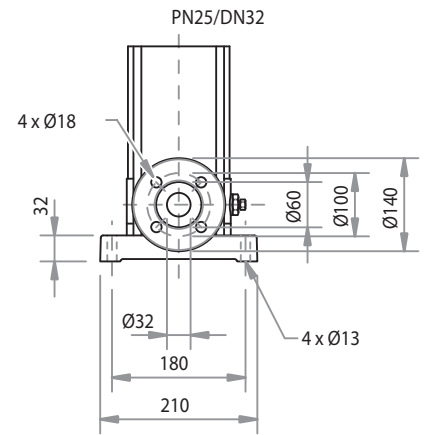
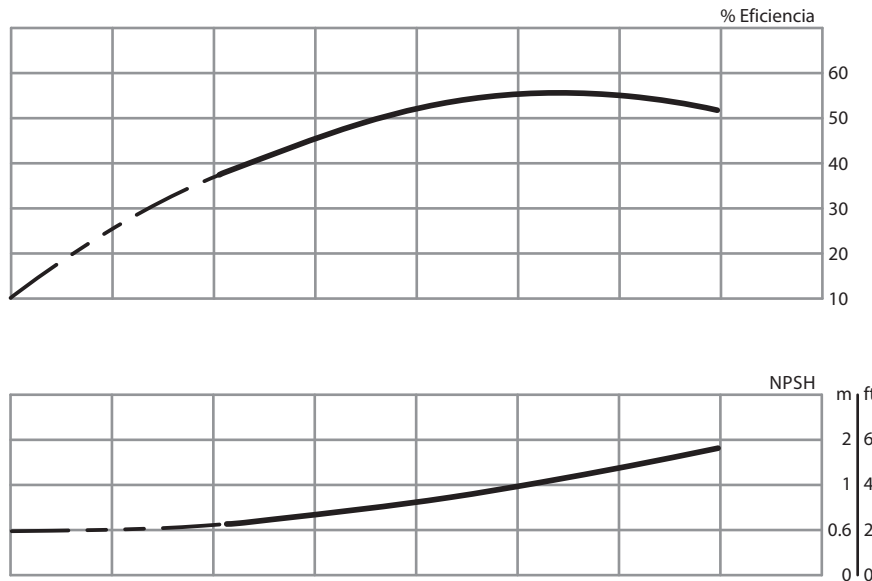
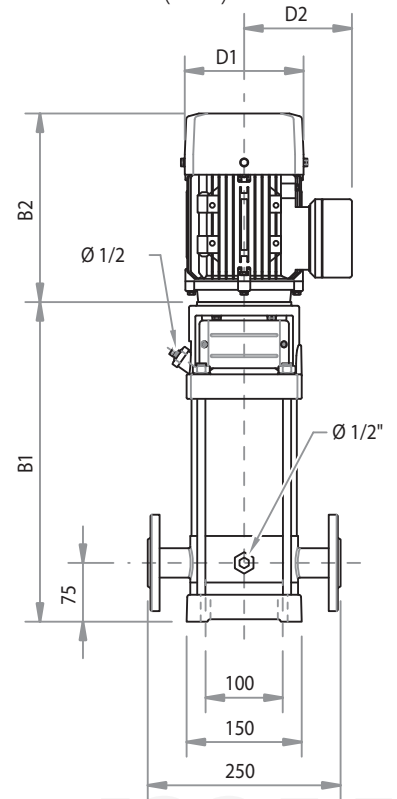
► CURVA DE RENDIMIENTO BMV8

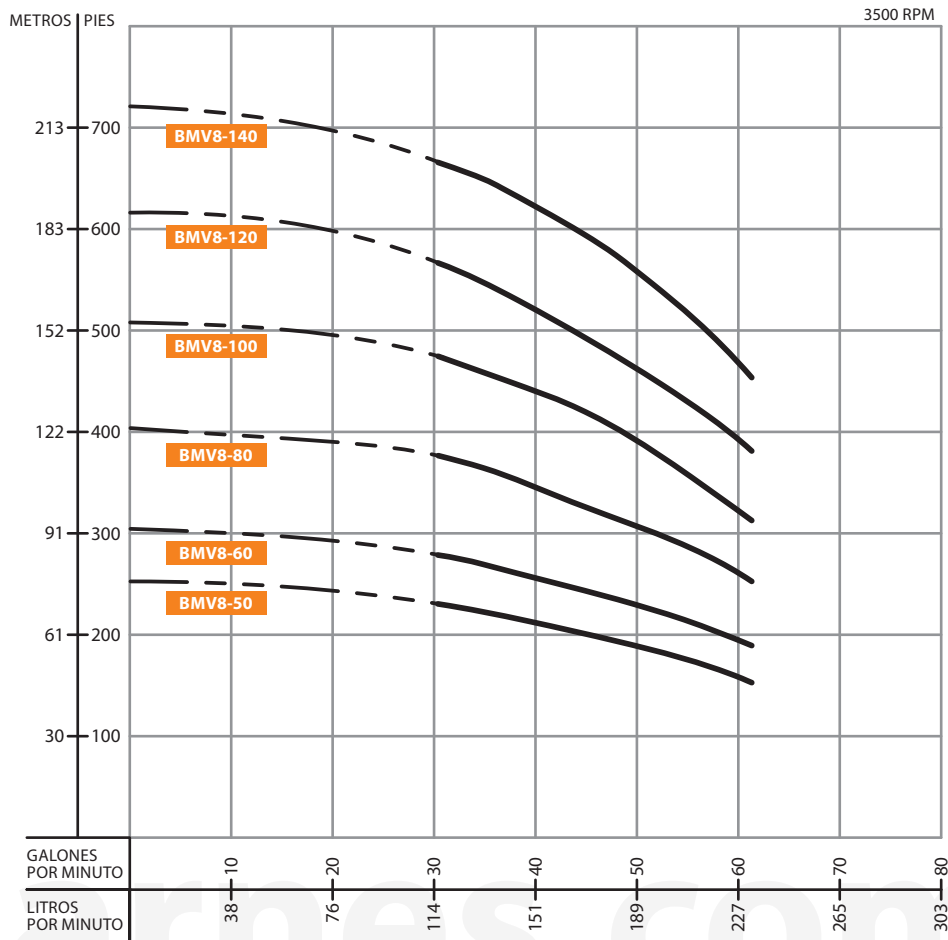

Dibujo de Instalación (mm)



Tabla de Rendimiento

MODELO	PASOS	HP	Q (LPM)	116.7	133.3	150	166.7	183.3	200	216.7	233.3
BMV8-50-403	5	4	H (m)	70	68	65	63	59	56	52	47
BMV8-60-503	6	5.5		85	82	78	76	72	68	62	57
BMV8-80-753	8	7.5		115	110	105	101	97	91	84	75
BMV8-100-1003	10	10		145	140	132	126	122	115	105	95
BMV8-120-1003	12	10		173	167	160	152	147	132	125	115
BMV8-140-1503	14	15		202	195	188	179	174	163	147	135

Dimensiones y Pesos

B1	B2	B1+B2	TAMAÑO (mm)		PESO (kg)
			D1	D2	
457	315	772	197	165	50
487	335	822	230	188	58
567	430	997	260	208	71
627	430	1057	260	208	80
687	430	1117	260	208	82
835	490	1325	330	255	153

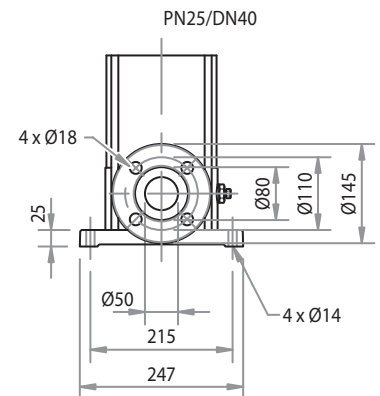
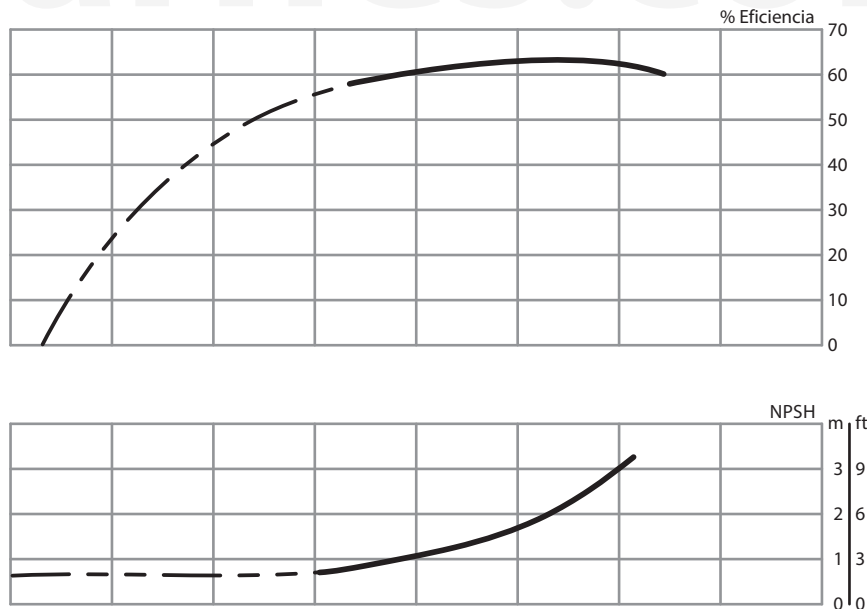
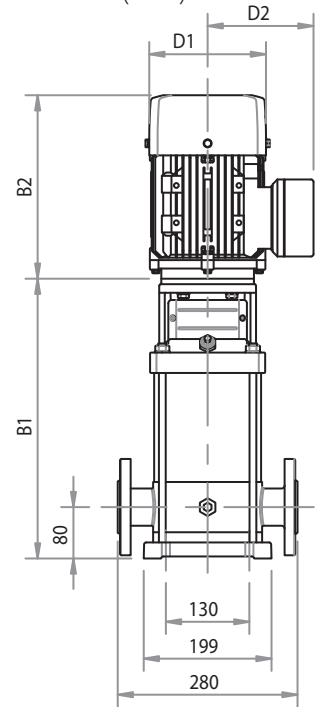
► CURVA DE RENDIMIENTO BMV12

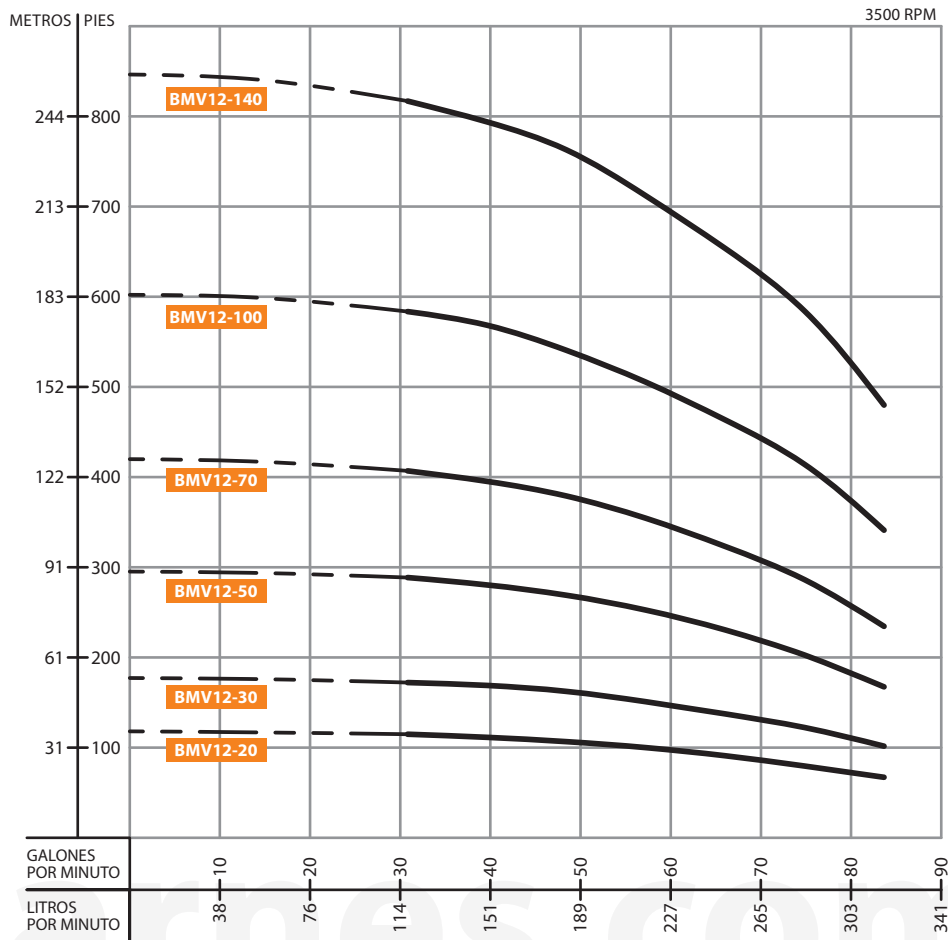

Dibujo de Instalación (mm)



Tabla de Rendimiento

MODELO	PASOS	HP	Q (LPM)	116.7	150	183.3	200	216.7	250	283.3	316.7
BMV12-20-303	2	3	H (m)	35	34	32.5	32	30.5	27	24.5	20.5
BMV12-30-503	3	5.5		52.5	51.5	50	48	46	41.5	37.5	31
BMV12-50-753	5	7.5		88	86	82	80	77	70	62	51
BMV12-70-1003	7	10		124	121	116	112	107	97	88	71
BMV12-100-1503	10	15		178	173	166	161	153	140	128	104
BMV12-140-2003	14	20		249	242	233	225	216	198	180	145

Dimensiones y Pesos

B1	B2	TAMAÑO (mm)				PESO (kg)
		B1+B2	D1	D2		
367	290	657	190	155	41	
407	335	742	230	188	56	
487	430	917	260	208	71	
547	430	977	260	208	78	
725	490	1215	330	255	151	
845	490	1335	330	255	167	

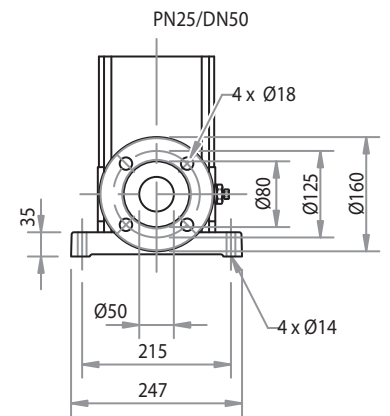
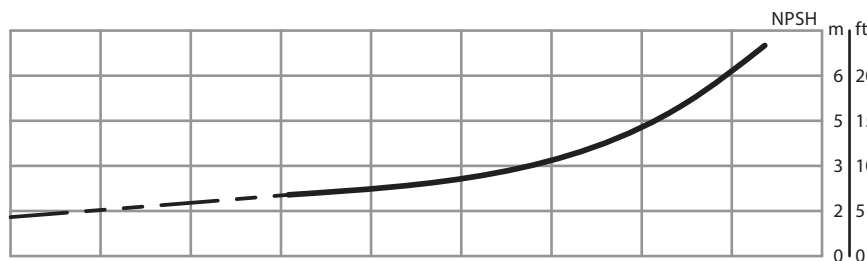
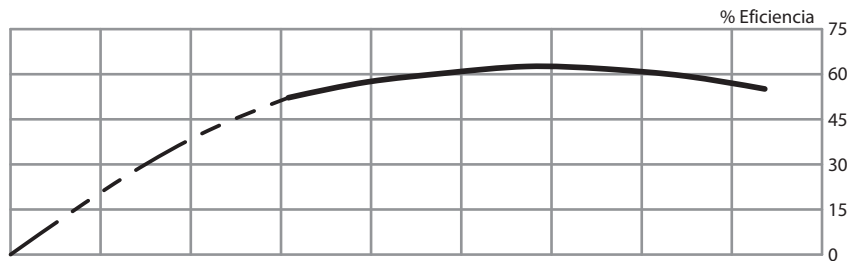
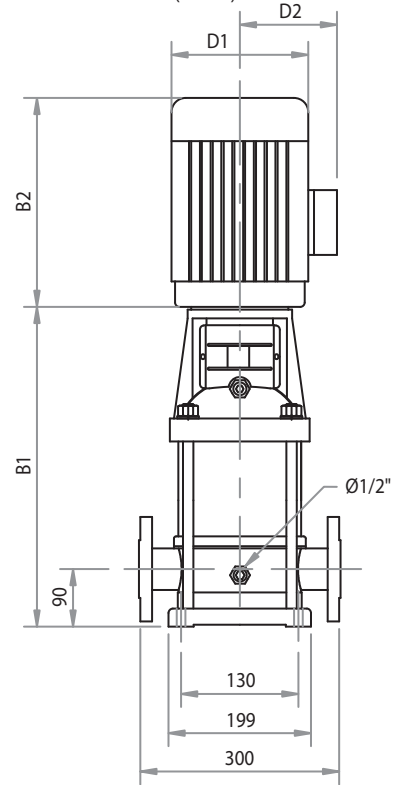
► CURVA DE RENDIMIENTO BMV16

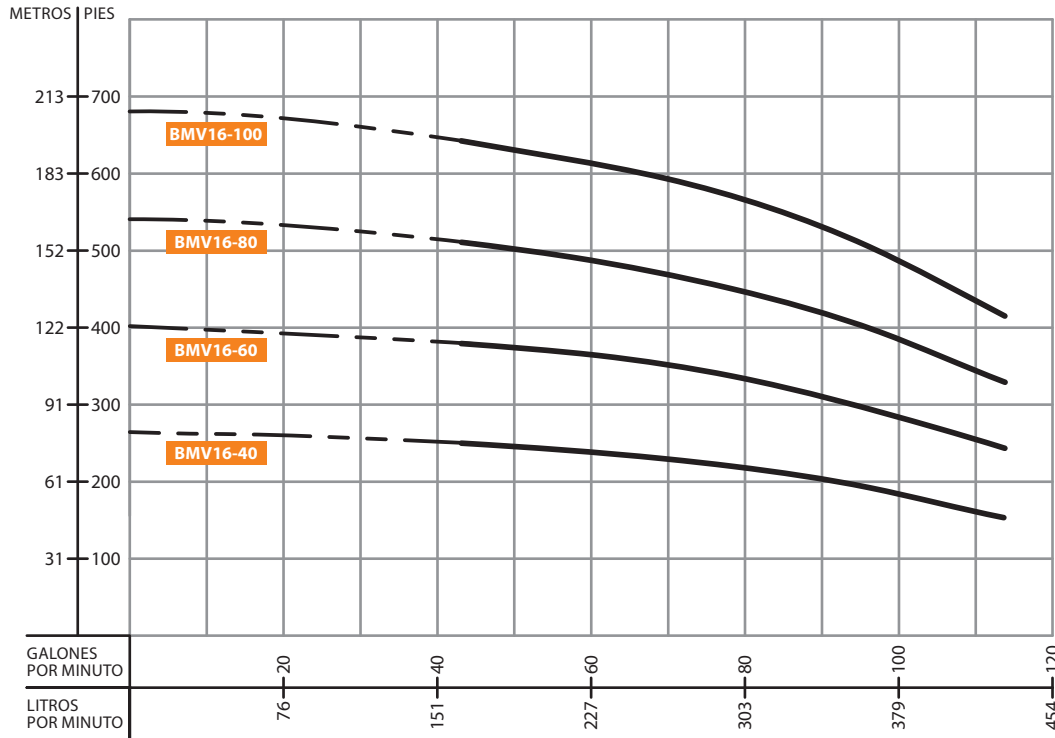

Dibujo de Instalación (mm)



Tabla de Rendimiento

MODELO	PASOS	HP	Q (LPM)	166.7	200	233.3	266.7	300	333.3	366.7	400	433.3
BMV16-40-1003	4	10	H (m)	76	75	73	72	68	64	60	54	49
BMV16-60-1503	6	15		115	113	111	108	102	96	91	82	75
BMV16-80-2003	8	20		155	152	148	144	137	130	122	111	101
BMV16-100-2503	10	25		197	192	187	181	174	165	153	139	127

Dimensiones y Pesos

TAMAÑO (mm)					PESO (kg)
B1	B2	B1+B2	D1	D2	
517	430	947	260	208	75
695	490	1185	330	255	150
785	490	1275	330	255	163
875	550	1425	330	255	186

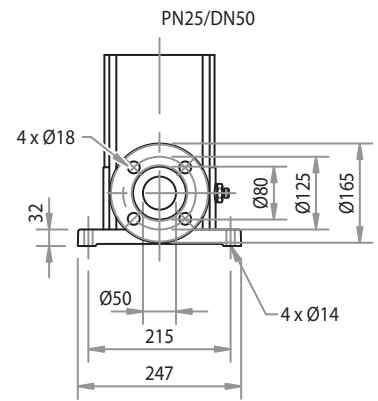
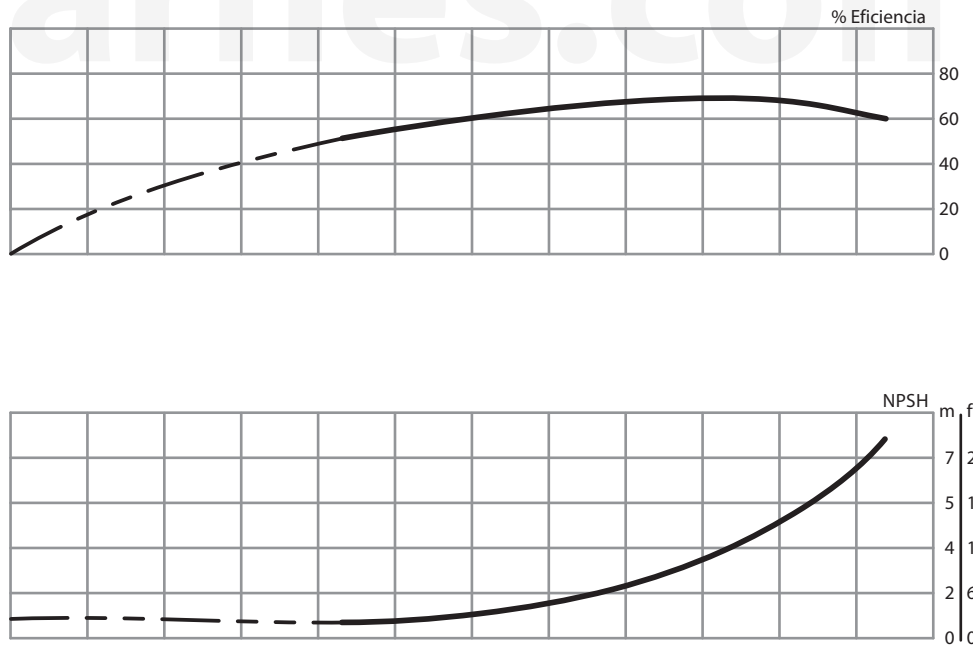
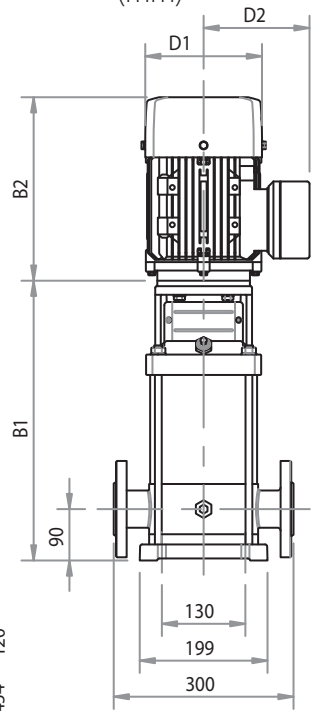
► CURVA DE RENDIMIENTO BMV20

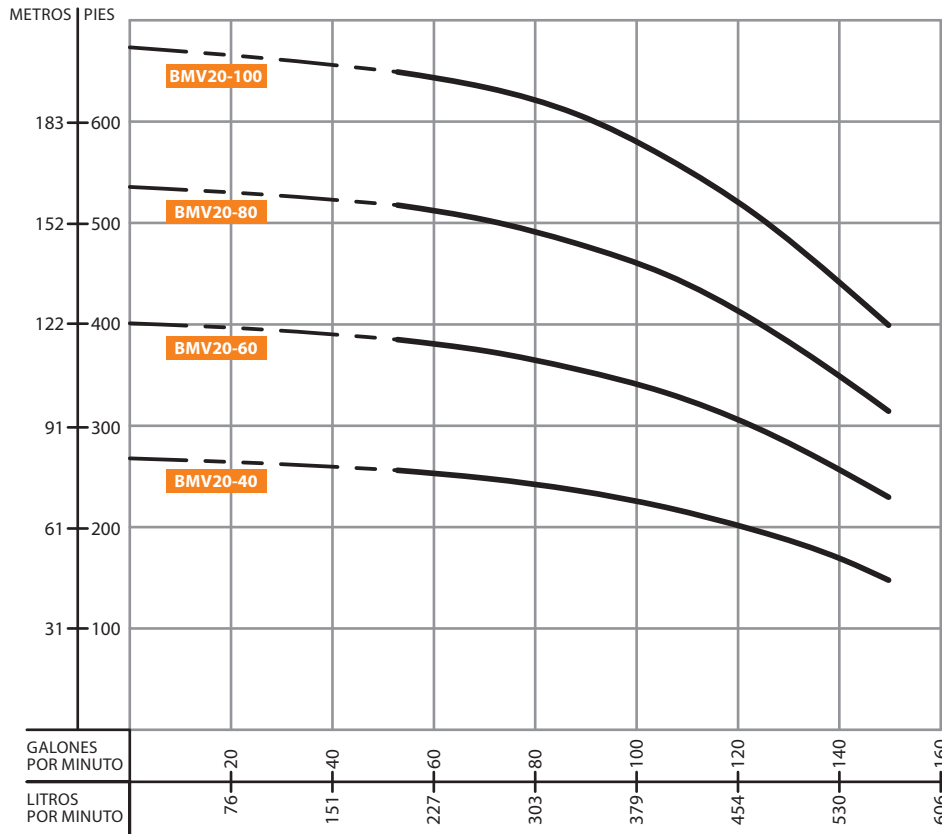

Dibujo de Instalación (mm)



Tabla de Rendimiento

MODELO	PASOS	HP	Q (LPM)	H (m)					
				200	266.7	333.3	400	466.7	533.3
BMV20-40-1003	4	10	78	75	72	67	60	51	45
BMV20-60-1503	6	15	118	113	108	102	91	77	70
BMV20-80-2003	8	20	158	153	146	137	123	105	96
BMV20-100-2503	10	25	198	193	185	172	155	133	122

Dimensiones y Pesos

TAMAÑO (mm)	PESO (kg)					
	B1	B2	B1+B2	D1	D2	
40	517	430	947	260	208	79
60	695	490	1185	330	255	150
80	785	490	1275	330	255	163
100	875	550	1425	330	255	187

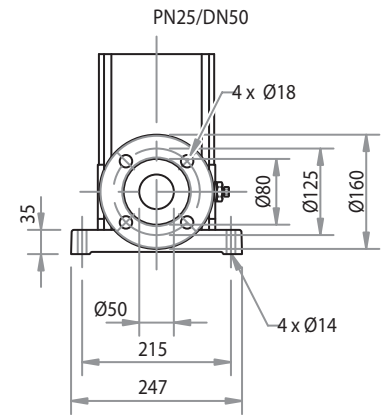
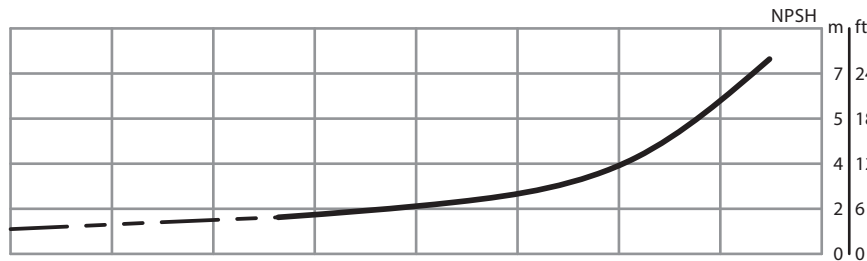
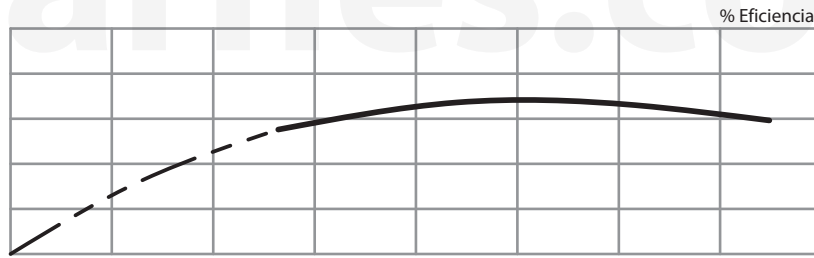
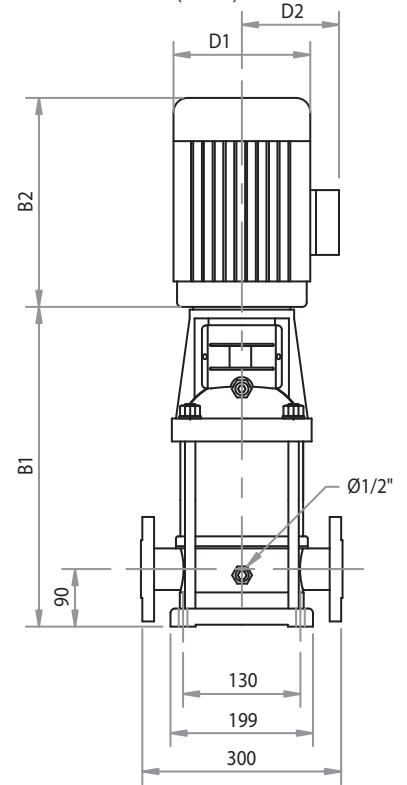
► CURVA DE RENDIMIENTO BMV32

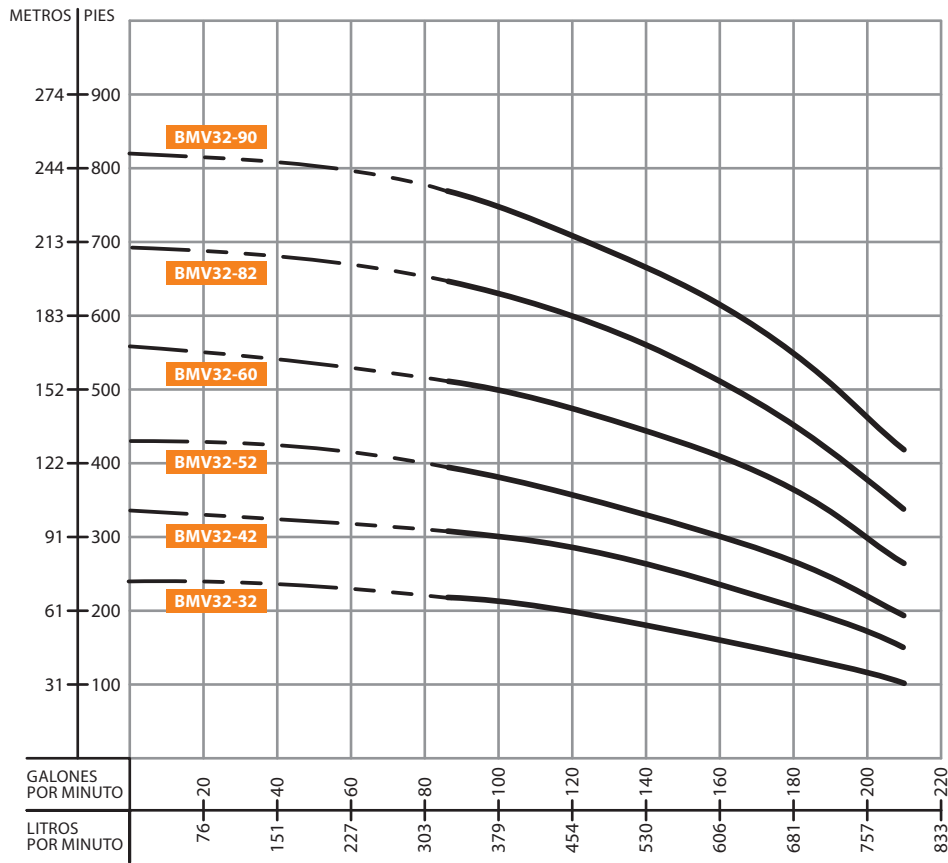

Dibujo de Instalación (mm)



Tabla de Rendimiento

MODELO	PASOS	HP	Q (LPM)	333.3	400	466.7	533.3	600	666.7	733.3	800
BMV32-32-1003	3	10	H (m)	67	64	61	57	52	46	39	31
BMV32-42-1503	4	15		94	91	87	81	73	65	56	45
BMV32-52-2003	5	20		119	115	109	102	94	84	73	59
BMV32-60-2503	6	25		155	150	144	136	126	114	100	81
BMV32-82-3003	8	30		196	190	182	172	159	143	124	102
BMV32-90-4003	9	40		234	226	216	204	189	172	152	127

Dimensiones y Pesos

TAMAÑO (mm)	PESO (kg)				
	B1	B2	B1+B2	D1	D2
645	490	1135	330	255	104
820	490	1310	330	255	176
890	490	1380	330	255	191
960	550	1510	330	255	216
1100	590	1690	400	310	259
1170	660	1830	400	310	319

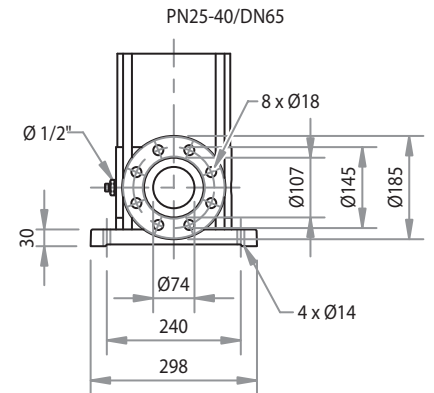
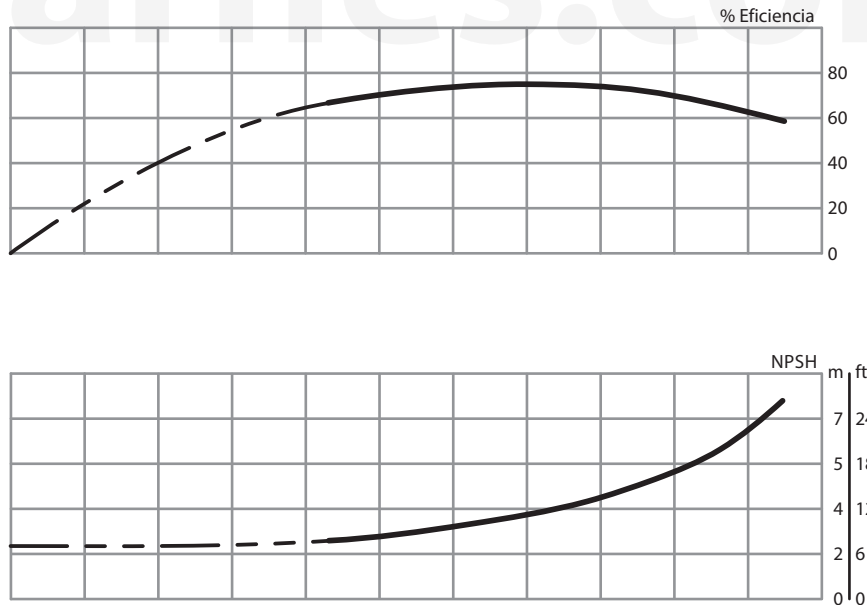
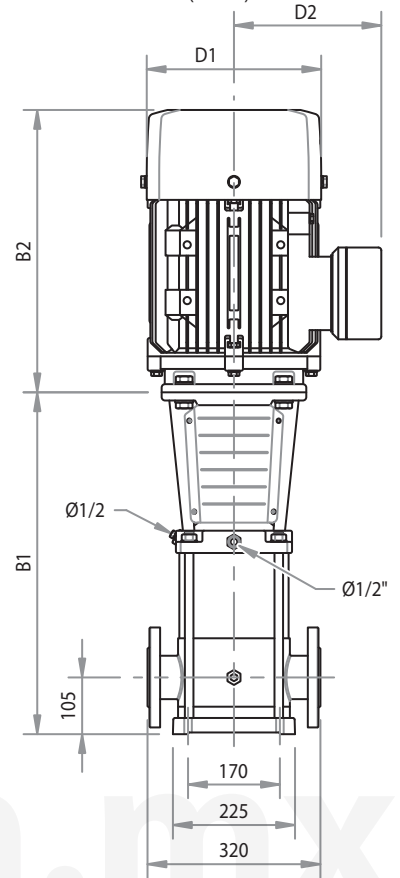
► CURVA DE RENDIMIENTO BMV42

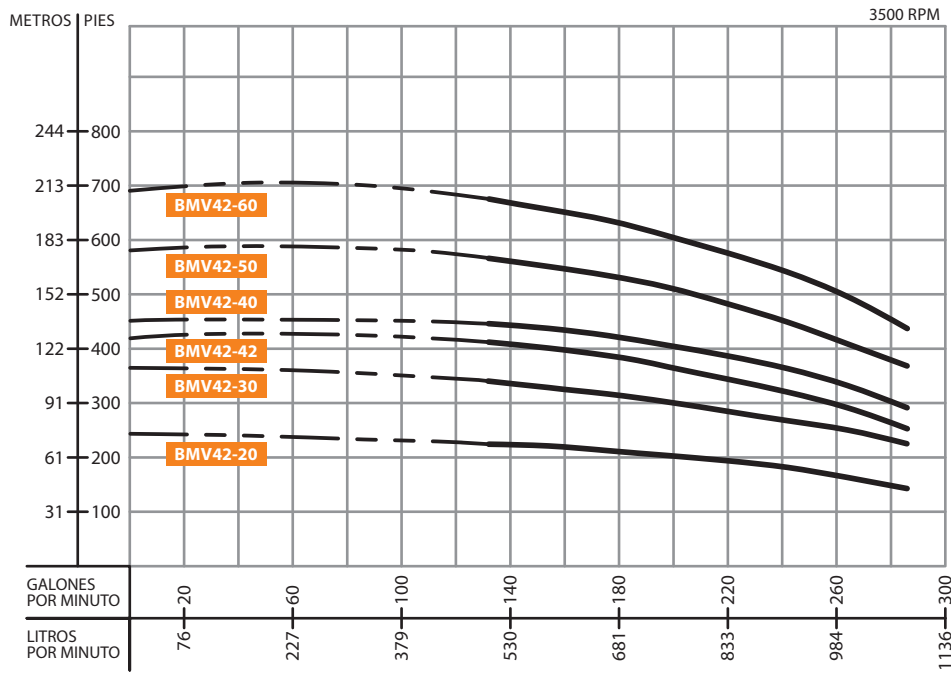

Dibujo de Instalación (mm)

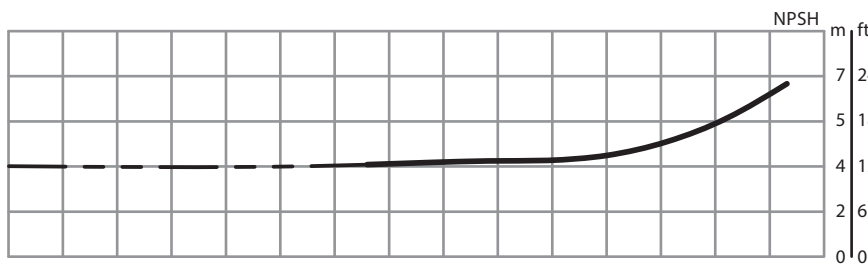
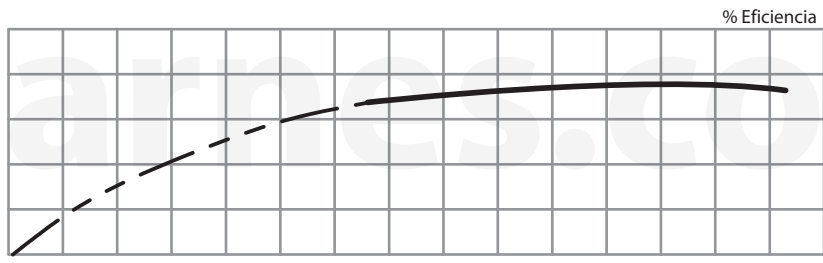
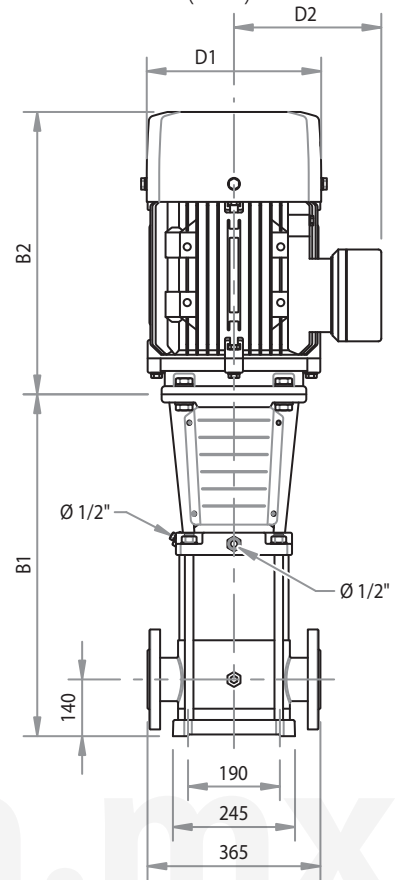

PN16-25/DN80



Tabla de Rendimiento

MODELO	PASOS	HP	Q (LPM)	500	583.3	666.7	700	750	833.3	916.7	1000	1083.3
BMV42-20-2003	2	20	H (m)	69	67	65	63	61	59	55	50	44
BMV42-30-2503	3	25		102	100	97	95	92	88	82	76	68
BMV42-42-3003	4	30		125	121	118	115	112	105	98	89	78
BMV42-40-4003	4	40		136	133	129	126	123	117	112	102	89
BMV42-50-4003	5	40		171	166	161	158	154	145	138	126	112
BMV42-60-5003	6	50		205	200	193	190	186	176	166	152	134

Dimensiones y Pesos

TAMAÑO (mm)					PESO (kg)
B1	B2	B1+B2	D1	D2	
748	490	1238	330	255	188
828	550	1378	330	255	213
908	590	1498	360	285	253
908	660	1568	400	310	309
988	660	1648	400	310	313
1068	660	1728	400	310	340

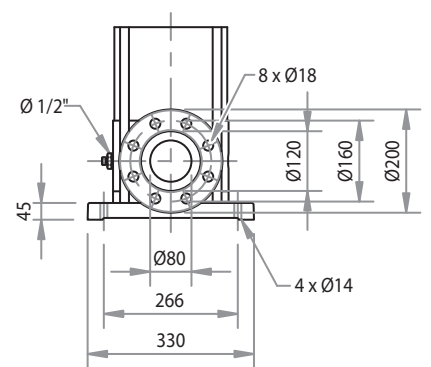
► CURVA DE RENDIMIENTO BMV65

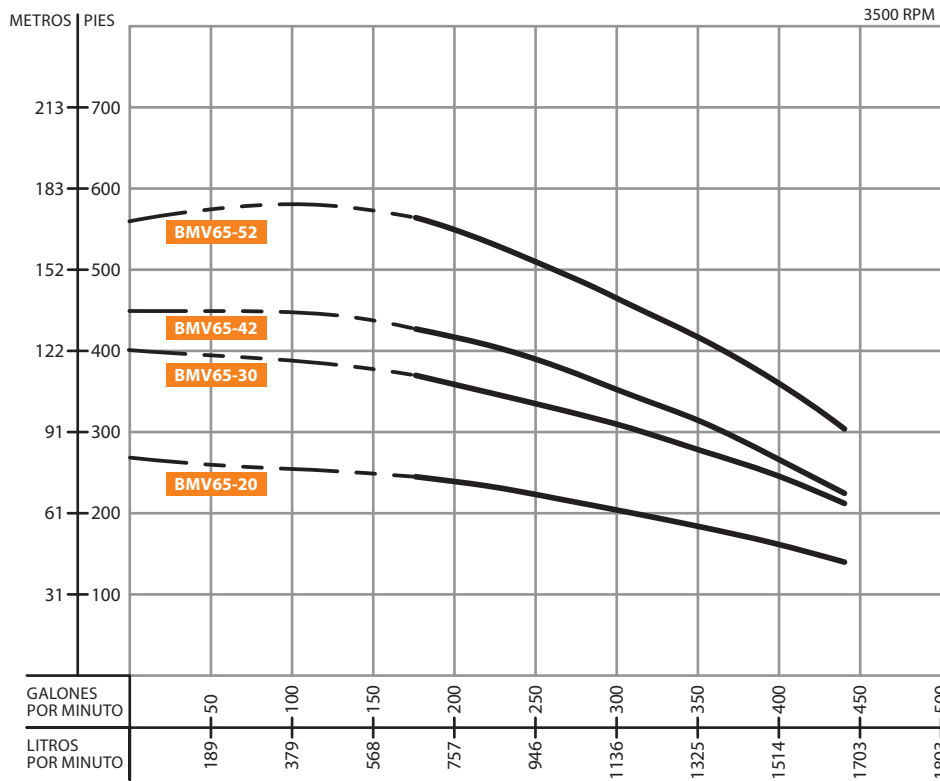

Dibujo de Instalación (mm)

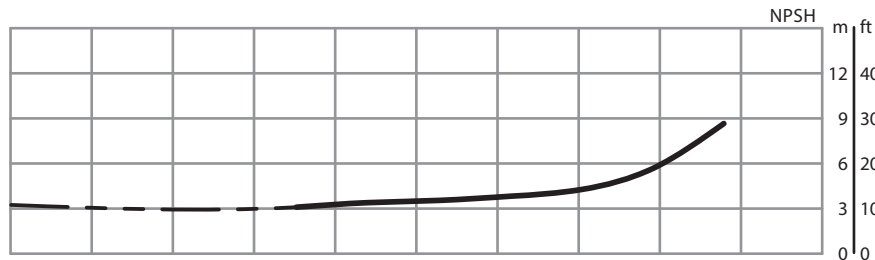
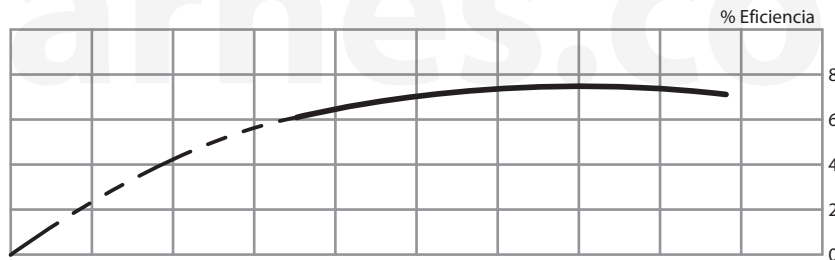
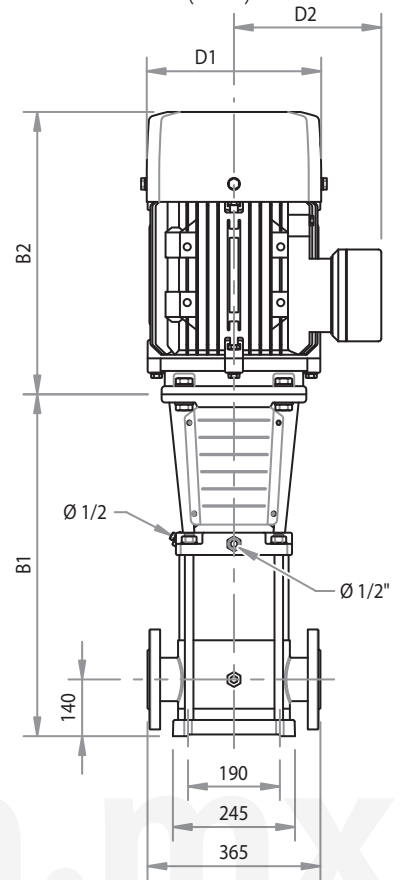

PN16-25/DN100



Tabla de Rendimiento

MODELO	PASOS	HP	Q (LPM)	666.7	833.3	1000	1083.3	1166.7	1333.3	1500	1666.7
BMV65-20-3003	2	30	H (m)	74	72	67	64	62	57	51	42
BMV65-30-4003	3	40		112	108	100	96	93	86	77	65
BMV65-42-5003	4	50		130	124	115	110	103	94	83	66
BMV65-52-6003	5	60		172	162	151	144	137	126	112	91

Dimensiones y Pesos

TAMAÑO (mm)					PESO (kg)
B1	B2	B1+B2	D1	D2	
754	590	1344	360	285	248
836	660	1496	400	310	313
919	660	1579	400	310	336
1001	700	1701	460	340	402

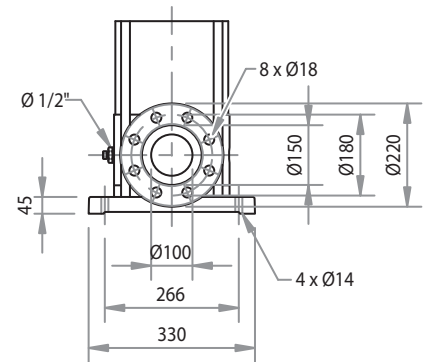
► CURVA DE RENDIMIENTO BMV90

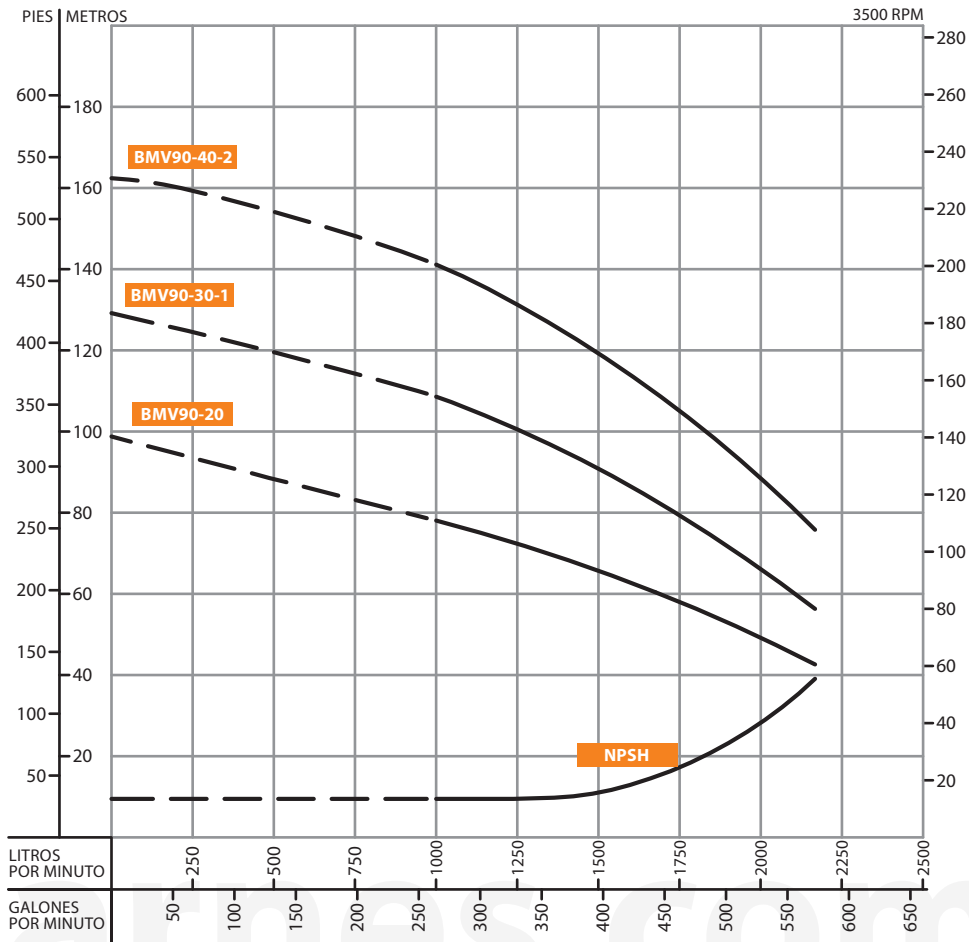

Dibujo de Instalación (mm)



Tabla de Rendimiento

MODELO	PASOS	HP	Q (m. ³ /h)	% Eficiencia									
				60	70	80	90	100	110	120	130		
BMV90-20	2	40		76	73	69	64	60	56	52	44		
BMV90-30-1	3	50	H (m)	108	104	98	90	83	78	69	56		
BMV90-40-2	4	60		141	135	128	118	109	102	89	72		

Dimensiones y Pesos

TAMAÑO (mm)					PESO (kg)
B1	B2	B1+B2	D1	D2	
773	660	1433	400	310	304
865	660	1525	400	310	330
957	700	1657	460	340	396

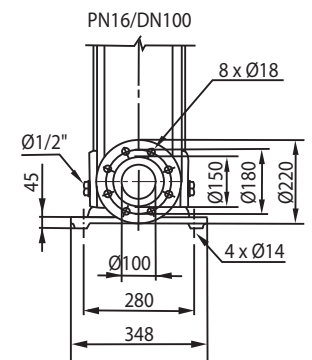
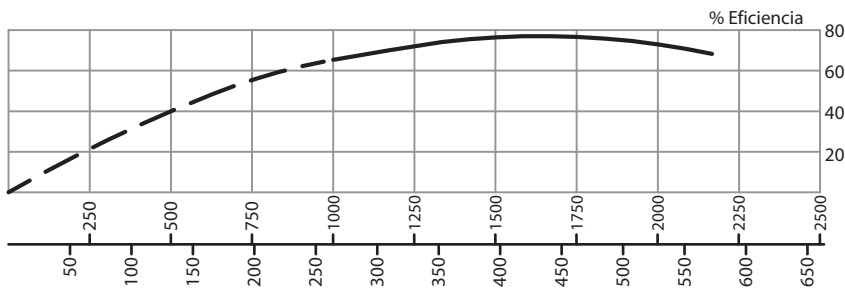
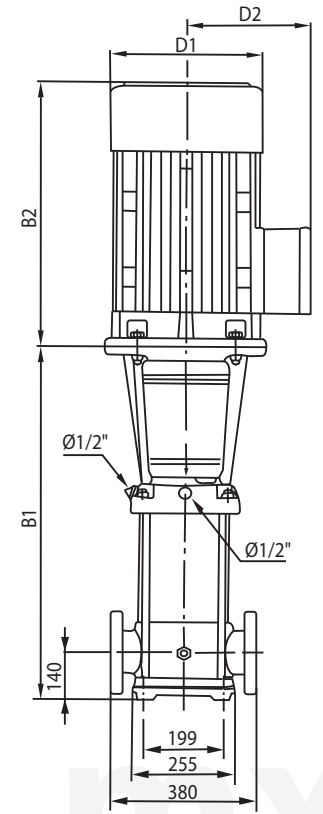
► CURVA DE RENDIMIENTO BMV120

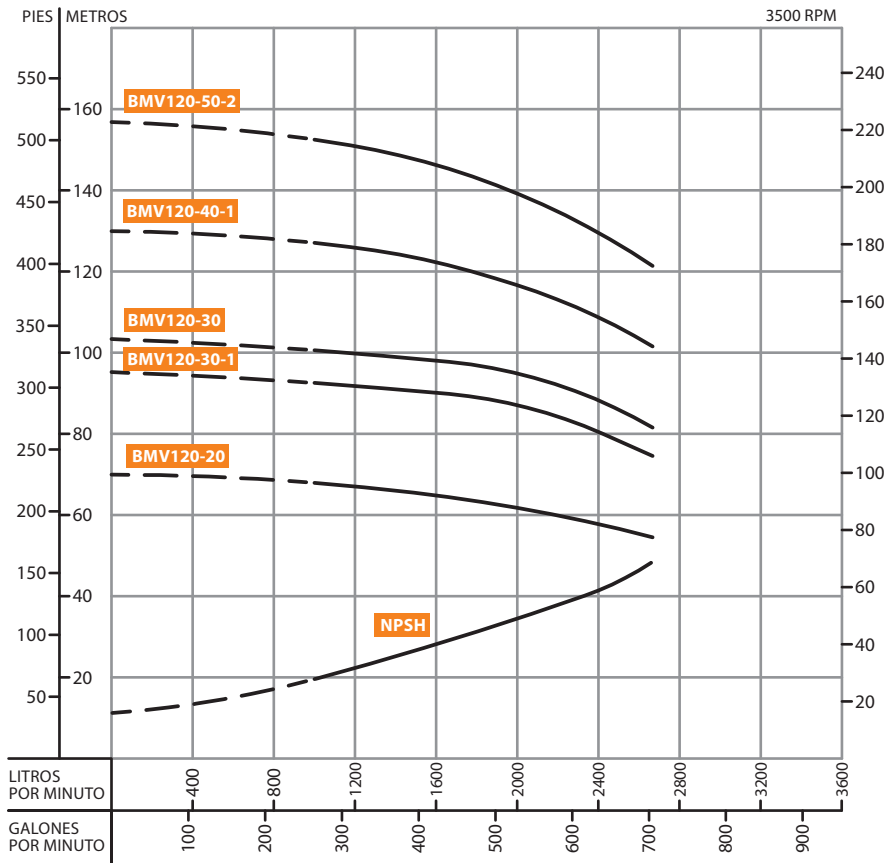

Dibujo de Instalación (mm)



Tabla de Rendimiento

MODELO	PASOS	HP	Q (m. ³ /h)	60	70	80	90	100	110	120	130	140	150	160
BMV120-20	2	50	H (m)	66.3	66	65.7	65	64.4	63	62	60.7	59.6	57	54.6
BMV120-30-1	3	60		91.3	91	90.4	89	87.7	86	84.4	82	80	76.7	73.3
BMV120-30	3	75		100.3	100	99.4	98.3	97.3	95.5	94	92	90	86.3	82.7
BMV120-40-1	4	100		126	125.4	124.6	122.6	120.6	118.5	116.5	114	111.3	107	103
BMV120-50-2	5	100		152	151	149.7	147	144	141.5	139	135.5	132	127	122

Dimensiones y Pesos

TAMAÑO (mm)					PESO (kg)
B1	B2	B1+B2	D1	D2	
1000	660	1660	400	310	380
1160	700	1860	460	340	445
1190	770	1960	510	370	545
1350	845	2195	580	410	675
1510	845	2355	580	410	690

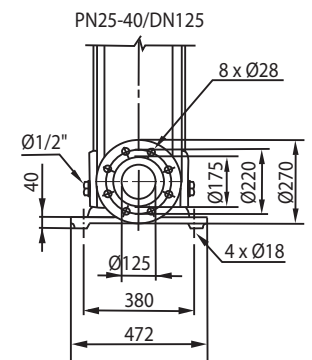
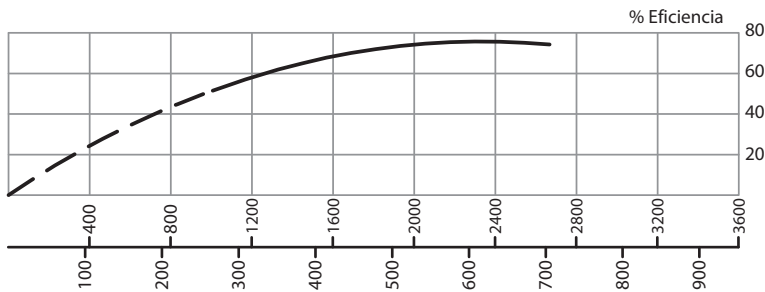
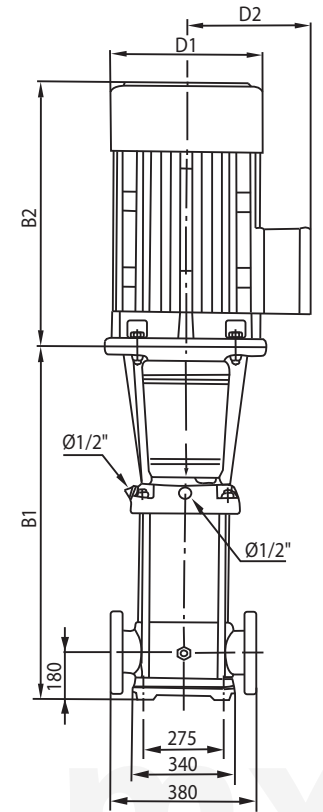
► CURVA DE RENDIMIENTO BMV150

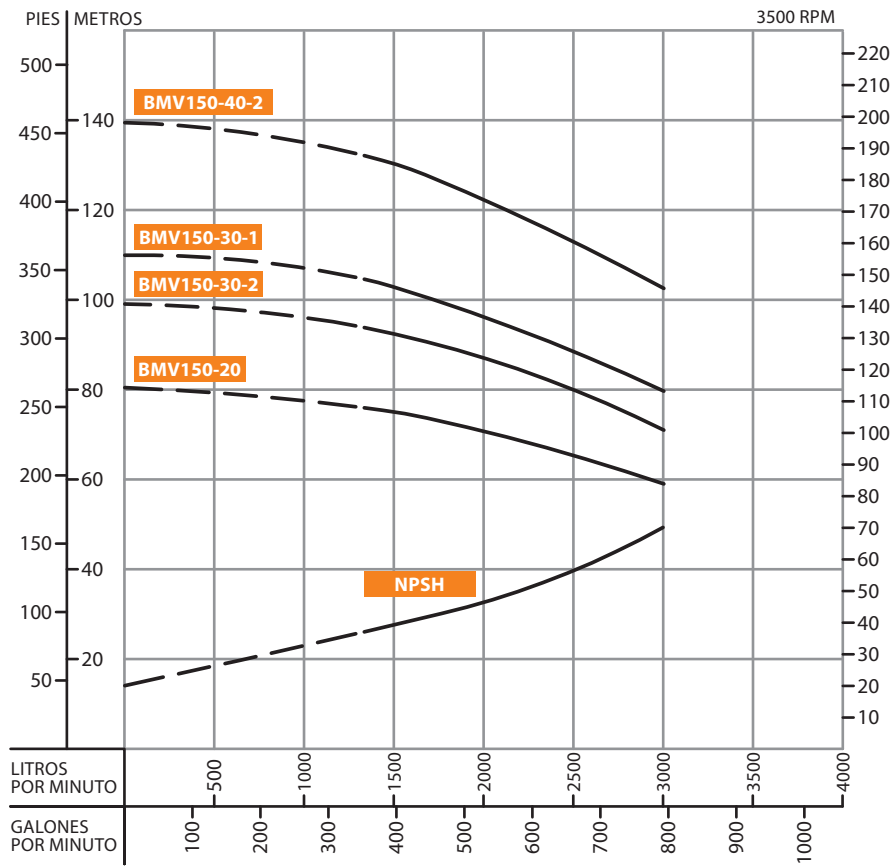

Dibujo de Instalación (mm)



Tabla de Rendimiento

MODELO	PASOS	HP	Q (m./h)	80	90	100	110	120	130	140	150	160	170	180
BMV150-20	2	60	H (m)	75.5	74.5	73.6	72	70.4	69	67.5	65.5	63.5	61	59
BMV150-30-2	3	75		94	92	90.5	88.4	86.4	83.8	81	80	78	75.3	72.5
BMV150-30-1	3	100		104	102.5	100	98	96	94	92	89	87	84	80
BMV150-40-2	4	100		133	130.3	127.6	124.6	121.7	118.3	115	112.5	110	106.3	102.5

Dimensiones y Pesos

TAMAÑO (mm)					PESO (kg)
B1	B2	B1+B2	D1	D2	
1000	700	1700	460	340	435
1190	770	1960	510	370	545
1190	845	2035	580	410	665
1350	845	2195	580	410	680

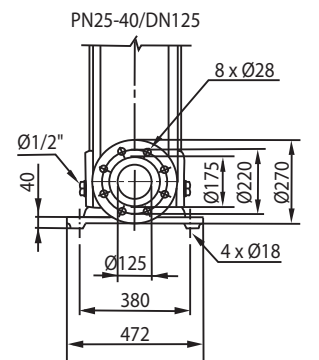
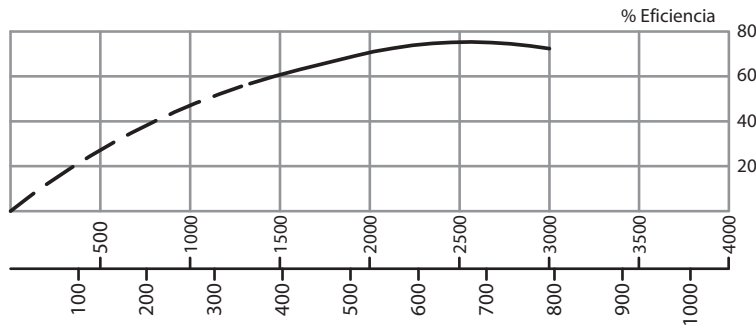
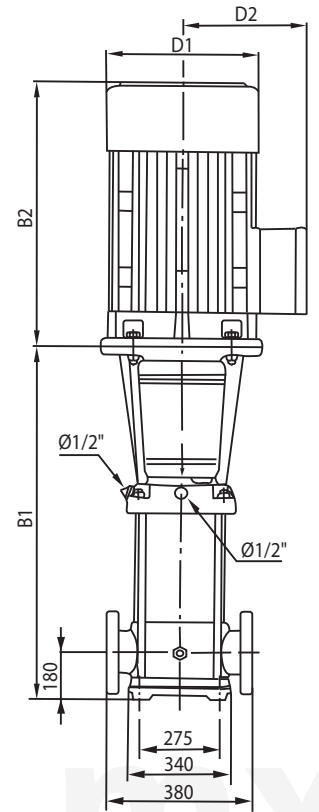
► CURVA DE RENDIMIENTO BMV200

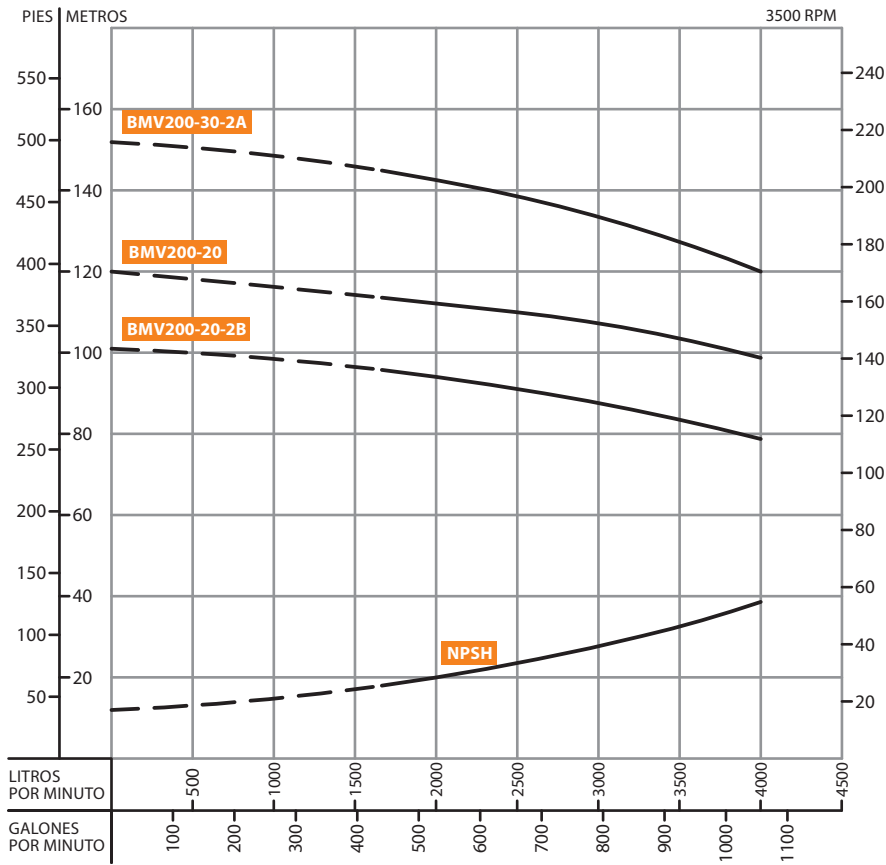

Dibujo de Instalación (mm)



Tabla de Rendimiento

MODELO	PASOS	HP	Q (m ³ /h)	H (m)							
				100	120	140	160	180	200	240	
BMV200-20-B	2	100		95.5	93.5	92.5	90.5	88.5	86	82.5	79
BMV200-20	2	120		114	112.5	111	109.5	107.5	105	101.5	98.5
BMV200-30-2A	3	150		145	142.5	140	137	133.5	130	125.5	120

Dimensiones y Pesos

B1	B2	B1+B2	TAMAÑO (mm)		PESO (kg)
			D1	D2	
1131	845	1976	580	410	718
1131	895	2026	580	410	787
1325	1140	2465	645	550	1158

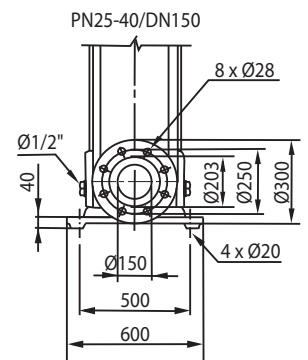
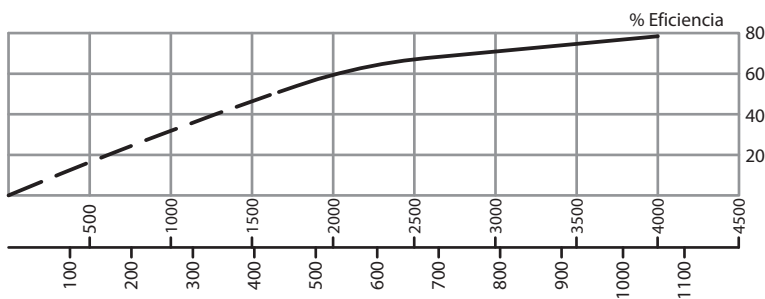
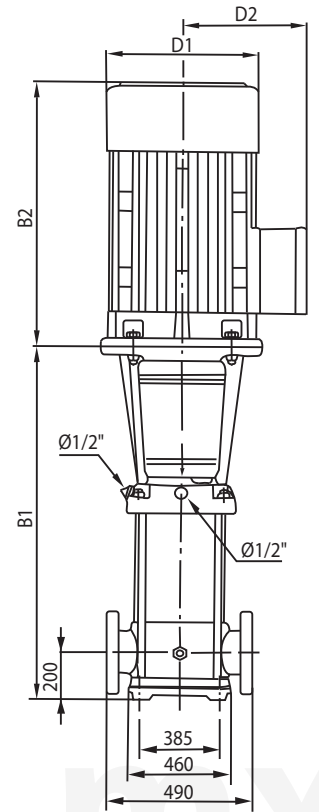
www.barmesa.com.mx

© Barnes de México, S.A. de C.V. Derechos reservados.